



DEPARTMENT OF THE ARMY  
U.S. ARMY CORPS OF ENGINEERS, SACRAMENTO DISTRICT  
1325 J STREET  
SACRAMENTO CA 95814-2922

March 24, 2022

Office of Counsel

SUBJECT: Freedom of Information Act Request No. FA-22-0079; Copies of Current/ Expired Permit Records, for Existing Buoys Field and/or Other Shore Zone Structures for Several Properties

Ms. Karin Hoida  
Basin Strategies Planning & Consulting  
1046 Lucerne Way  
Incline Village, Nevada 89451

Dear Ms. Hoida:

On March 8, 2022, our office received your Freedom of Information Act (FOIA) request for copies of current/ expired permit records, for existing buoys field and/or other shore zone structures for several properties owned by Incline Beach Association, Bunker Trust, Ingermanson, and/or Tahoe Palm listed below:

- 1625 Pine Cone Circle, APN 130-241-37
- 1655 Pine Cone Circle, APN 130-241-39
- 1665 Pine Cone Circle, APN 130-241-40
- 1675 Pine Cone Circle, APN 130-241-56

For the purpose of assessing fees, I have classified you as a category 3 ("other") requester under 32 C.F.R. § 286.12(a). Category 3 requesters are entitled to two hours of search time and 100 pages of records free of charge. See id. § 286.12(e)(4). After reduction of the processing costs by these amounts, the charges for providing the requested information are less than \$15.00, therefore there is no fee for this request.

A redacted copy of the requested documents is attached. Although a majority of the information requested has been provided, names of Department of Defense (DoD) employees contained in the headers of e-mails and other similar lists of names within the records have been redacted pursuant to 5 U.S.C. §§ 552(b)(3),(6) of the FOIA. These provisions, known as Exemptions 3 and 6, exempt from disclosure any information specifically exempted from disclosure by statute, along with personnel and medical files the disclosure of which would constitute a clearly unwarranted invasion of personal privacy. Pursuant to 10 U.S.C. § 130b(a), personally identifying information may be withheld from disclosure regarding any member of the armed forces assigned to an overseas unit, a sensitive unit, or a routinely deployable unit. See also Hall v. C.I.A., 881 F. Supp. 2d 38, 66 (D.D.C. 2012); Dep't of Defense, Manual 5400.07 ¶ 5.2(c)(2)(a) (Jan. 25, 2017).

Also, names of private individuals and their addresses contained in the permit documentations have been redacted pursuant to 5 U.S.C. § 552 (b)(6) of the Freedom of Information Act. Exemption 6 protects privacy interests to the extent that information about individuals is contained in personnel, medical and similar files, when the disclosure of such information would constitute a clearly unwarranted invasion of privacy. See, Strout v. United States Parole Comm'n, 40 F.3d 136, 139 (6th Cir. 1994).

This office will conduct another search if you can provide additional information which may assist us in locating additional requested materials, such as date, title or name, author, recipient, and subject matter of the record sought/title of court case, the court in which the case was filed, and the nature of case/file designations or descriptions for records sought.

Additionally, because your request has been partially denied, you are advised of your right to appeal this determination through this office to the Secretary of the Army (ATTN: General Counsel). Your appeal must be postmarked or electronically transmitted within 90 days of the date of this letter. Your appeal should clearly identify the determination that is being appealed, along with the assigned FOIA request number. The envelope containing the appeal should bear the notation "Freedom of Information Act Appeal" and should be sent to U.S. Army Corps of Engineers, Sacramento District, ATTN: CESP-K-OC, 1325 J Street, Room 1440, Sacramento, California 95814.

For any further assistance or to discuss any aspect of your request, you have the right to contact the U.S. Army Corps of Engineers FOIA Public Liaison. Additionally, you have the right to contact the Office of Government Information Services (OGIS) to inquire about FOIA mediation services they offer. Contact Information:

U.S. Army Corps of Engineers  
FOIA Public Liaison  
441 G. Street, NW  
ATTN: CECC-L (Emily Green)  
Washington, DC 20314-1000  
Email: foia-liaison@usace.army.mil  
Phone: 202-761-4791

Office of Government Information Services  
National Archives and Records Administration  
8601 Adelphi Road-OGIS  
College Park, MD 20740-6001  
E-Mail: ogis@nara.gov  
Phone: 202-741-5770 or  
Toll Free: 877-684-6448

If you have any questions regarding the provided information, please contact Ms. Andrea L. Vaiasicca, FOIA Specialist, at the above letterhead address or by phone at (916) 557-7204.

Sincerely,



A. L. Faustino  
District Counsel  
Initial Denial Authority

Enclosures

FOIA Requester Service Center  
CESPK-OC  
1325 J St  
Sacramento, CA 95814-2922  
Sent via email: [FOIA-SPK@usace.army.mil](mailto:FOIA-SPK@usace.army.mil)

March 8, 2022

To Whom It May Concern:

This is a request under the Freedom of Information Act (5 U.S.C. § 552).

I request that a copy of the following document(s) be provided to me:

Any permit records on file for the existing buoy field and/or other shorezone structures (even if expired) for any or all of the following:

Owners: Incline Beach Association, Bunker Trust, Ingemanson, and/or Tahoe Palm Springs LLC

Addresses & APNs (all in Incline Village, NV 89451):

1. 1625 Pine Cone Circle, APN 130-241-37
2. 1655 Pine Cone Circle, APN 130-241-39
3. 1665 Pine Cone Circle, APN 130-241-40
4. 1675 Pine Cone Circle, APN 130-241-56

GPS coordinates of the general areas:

39.233386, -119.936773

39.231982, -119.935485

In case helpful, the project area is located in Washoe County, Nevada.

In order to help you determine my status for the purpose of assessing fees, you should know that I am a representative seeking information for the personal use of my clients,

the owners of these properties, and not for a commercial use.

I am willing to pay the appropriate fees for this request, however, please let me know what that cost will be ahead of processing this request.

Please feel free to call me at (775) 671-0559 or email [basinstrategies@gmail.com](mailto:basinstrategies@gmail.com). I would prefer all records to be emailed if possible.

Thank you!

A handwritten signature in dark ink, appearing to read 'Karin Hoida', with a stylized flourish at the end.

Karin Hoida  
Basin Strategies Planning & Consulting  
1046 Lucerne Way  
Incline Village, NV 89451



DEPARTMENT OF THE ARMY  
U.S. ARMY ENGINEER DISTRICT, SACRAMENTO  
CORPS OF ENGINEERS  
1325 J STREET  
SACRAMENTO CA 95814-2922

REPLY TO  
ATTENTION OF

April 21, 2014

Regulatory Division (SPK-1995-00724-NO)

Ben J. and Jude Lipps  
930 Tahoe Boulevard, No. 802-545  
Incline Village, Nevada 89451

Dear Mr. and Mrs. Lipps:

We are responding to your consultant's request for ownership transfer acknowledgement of four (4) existing structures, specifically one (1) pier, one (1) boatlift and two (2) mooring buoys lakeward of subject parcel (APN 130-241-39) The project is located in Lake Tahoe; Section 23, Township 16 North, Range 18 East; Latitude 39.23240°, Longitude -119.93547°, 1655 Pine Cone Circle, Incline Village, Washoe County, Nevada. This letter serves as acknowledgement that we have updated our records to show that you are the new owner of the referenced property and will assume responsibility for the pier, boatlift and mooring buoys.

Please note that in order for the permit transfer to be fully authorized, you must obtain all other required Federal, state, and local approvals, leases, or permits.

We appreciate your feedback. At your earliest convenience, please tell us how we are doing by completing the customer survey on our website under *Customer Service Survey*.

Please refer to identification number SPK-1995-00724 in any correspondence concerning this project. If you have any questions, please contact me at our Reno Field Office, 300 Booth Street, Room 3050, Reno, Nevada 89509, email (b) (6) @usace.army.mil, or telephone 775-784-5305. For more information regarding our program, please visit our website at [www.spk.usace.army.mil/regulatory.aspx](http://www.spk.usace.army.mil/regulatory.aspx).

Sincerely,

-Original Signed By-

(b) (6)  
Regulatory Specialist, Reno Field Office  
Sacramento District

Copies furnished:

Kevin Agan, Agan Consulting Corporation, [kevin@aganconsulting.com](mailto:kevin@aganconsulting.com) and  
[office@aganconsulting.com](mailto:office@aganconsulting.com)  
Nevada State Lands Commission, [dmalow@lands.nv.gov](mailto:dmalow@lands.nv.gov)  
Tahoe Regional Planning Agency, [dlandry@trpa.org](mailto:dlandry@trpa.org)

January 5, 1996

Regulatory Branch (199500724) 3296

Kevin Agan Land & Shorezone Consultant  
P.O. Box 171  
Tahoe City, California 96145

Dear Mr. Agan:

We have received the application you submitted on behalf of Robert Martini and Edward Horgan, for a Department of the Army permit to modify their multiple-use pier. The project is located in Lake Tahoe within Section 23, Township 16 North, Range 18 East at Washoe County Assessor's Parcel Numbers 130-241-39/40, Nevada.

The Sacramento District has issued General Permit Number 16 for construction, modification, and repair work in Lake Tahoe. A copy of the general permit is enclosed for your review. Based on the information you provided, it appears your proposal could be authorized under this permit provided you obtain approvals from the Tahoe Regional Planning Agency and all other required state and local agencies. When you have obtained the necessary approvals please remit them to this office. At that time we will issue a letter of authorization for your project.

If you have any questions concerning our general permit, please write to (b) (6), Room 1480, or telephone (916) 557-7772.

Sincerely,

(b) (6)  
Chief, Nevada Office

Enclosure

Copies Furnished: w/o enclosure

Jim Lawrence, Tahoe Regional Planning Agency, P.O. Box 1038,  
Zephyr Cove, Nevada 89448-1038  
Environmental Services, Region II, Department of Fish and Game,  
1701 Nimbus Road, Rancho Cordova, California 95670  
Ed Bittleston, Nevada Division of State Lands, 333 West Nye  
Lane, Room 118, Carson City, Nevada 89710  
Mrs. Helen Denny, U.S. Coast Guard, Eleventh Coast Guard  
District, 501 West Ocean Blvd., Long Beach, California  
90822-5399  
Mr. Robert E. Martini, 1655 Pine Cone Circle, Incline Village,  
Nevada 89450  
Mr. Edward J. Horgan, 1665 Pine Cone Circle, Incline Village,  
Nevada 89450

January 5, 1996

Regulatory Branch (199500724) 3296

Kevin Agan Land & Shorezone Consultant  
P.O. Box 171  
Tahoe City, California 96145

Dear Mr. Agan:

We have received the application you submitted on behalf of Robert Martini and Edward Horgan, for a Department of the Army permit to modify their multiple-use pier. The project is located in Lake Tahoe within Section 23, Township 16 North, Range 18 East at Washoe County Assessor's Parcel Numbers 130-241-39/40, Nevada.

The Sacramento District has issued General Permit Number 16 for construction, modification, and repair work in Lake Tahoe. A copy of the general permit is enclosed for your review. Based on the information you provided, it appears your proposal could be authorized under this permit provided you obtain approvals from the Tahoe Regional Planning Agency and all other required state and local agencies. When you have obtained the necessary approvals please remit them to this office. At that time we will issue a letter of authorization for your project.

If you have any questions concerning our general permit, please write to (b) (6), Room 1480, or telephone (916) 557-7772.

Sincerely,

(b) (6)  
Chief, Nevada Office

(b) (6)

Enclosure

Copies Furnished: w/o enclosure

Jim Lawrence, Tahoe Regional Planning Agency, P.O. Box 1038,  
Zephyr Cove, Nevada 89448-1038  
Environmental Services, Region II, Department of Fish and Game,  
1701 Nimbus Road, Rancho Cordova, California 95670  
Ed Bittleston, Nevada Division of State Lands, 333 West Nye  
Lane, Room 118, Carson City, Nevada 89710  
Mrs. Helen Denny, U.S. Coast Guard, Eleventh Coast Guard  
District, 501 West Ocean Blvd., Long Beach, California  
90822-5399  
Mr. Robert E. Martini, 1655 Pine Cone Circle, Incline Village,  
Nevada 89450  
Mr. Edward J. Horgan, 1665 Pine Cone Circle, Incline Village,  
Nevada 89450

cc: Nev Off, Reg Br



C

KEVIN AGAN LAND & SHOREZONE CONSULTANT  
PO BOX 171  
TAHOE CITY CA 96145

C

JIM LAWRENCE  
TAHOE REGIONAL PLANNING AGENCY  
PO BOX 1038  
ZEPHYR COVE NV 89448-1038

C

ED BITTLESTON  
NEVADA DIVISION OF STATE LANDS  
333 WEST NYE LANE ROOM 118  
CARSON CITY NV 89710

C

MRS HELEN DENNY  
US COAST GUARD  
ELEVENTH COAST GUARD DISTRICT  
501 WEST OCEAN BLVD  
LONG BEACH CA 90822-5399

C

MR ROBERT E MARTINI  
1655 PINE CONE CIRCLE  
INCLINE VILLAGE NV 89450

C

MR EDWARD J HORGAN  
1665 PINE CONE CIRCLE  
INCLINE VILLAGE NV 89450

November 12, 1996

Regulatory Branch (199500724) 3296 GP-16

Kevin Agan Land & Shorezone Consultant  
P.O. Box 171  
Tahoe City, California 96145

Dear Mr. Agan:

We have reviewed the application submitted on behalf of Robert Martini and Edward Horgan for a Department of the Army permit to modify and existing pierhead on a 135-foot pier and install two boatlifts. This project is located in Lake Tahoe at Mile 60.20, Washoe County Assessor's Parcel Number 130-241-39 & 40 at 1655 & 1665 Pine Cone Circle, Incline Village, Nevada. Your project may be constructed under the authority of our General Permit 16 for construction, modification and repair work in the Lake Tahoe Basin, provided the work does not deviate from your drawings, dated January, 1996, and complies with the enclosed conditions of General Permit Number 16 and your state and local permits.

Number 199500724 has been assigned to your file. This verification is valid for a period of two years from the date of this letter. You should contact this office if work will extend beyond this date.

If you have any questions concerning this general permit, please write to (b) (6), Room 1480, at the letterhead address, or telephone (916) 557-7772.

Sincerely,

(b) (6)  
Chief, Nevada Office

Enclosure

Copies Furnished: with enclosure

Robert Martini, 1655 Pine Cone Circle,  
Incline Village, Nevada 89450  
Edward Horgan, 1665 Pine Cone Circle,  
Incline Village, Nevada 89450  
Jim Lawrence, Tahoe Regional Planning Agency, P.O. Box 1038,  
Zephyr Cove, Nevada 89448-1038  
Ron Pacheco, Nevada Division of State Lands, 333 West Nye Lane,

Room 118, Carson City, Nevada 89710



November 12, 1996

Regulatory Branch (199500724) 3296 GP-16

Kevin Agan Land & Shorezone Consultant  
P.O. Box 171  
Tahoe City, California 96145

Dear Mr. Agan:

We have reviewed the application submitted on behalf of Robert Martini and Edward Horgan for a Department of the Army permit to modify and existing pierhead on a 135-foot pier and install two boatlifts. This project is located in Lake Tahoe at Mile 60.20, Washoe County Assessor's Parcel Number 130-241-39 & 40 at 1655 & 1665 Pine Cone Circle, Incline Village, Nevada. Your project may be constructed under the authority of our General Permit 16 for construction, modification and repair work in the Lake Tahoe Basin, provided the work does not deviate from your drawings, dated January, 1996, and complies with the enclosed conditions of General Permit Number 16 and your state and local permits.

Number 199500724 has been assigned to your file. This verification is valid for a period of two years from the date of this letter. You should contact this office if work will extend beyond this date.

If you have any questions concerning this general permit, please write to (b) (6), Room 1480, at the letterhead address, or telephone (916) 557-7772.

Sincerely,

(b) (6)  
Chief, Nevada Office

Enclosure

Copies Furnished: with enclosure

Robert Martini, 1655 Pine Cone Circle,  
Incline Village, Nevada 89450  
Edward Horgan, 1665 Pine Cone Circle,  
Incline Village, Nevada 89450  
Jim Lawrence, Tahoe Regional Planning Agency, P.O. Box 1038,  
Zephyr Cove, Nevada 89448-1038  
Ron Pacheco, Nevada Division of State Lands, 333 West Nye Lane,

(b) (6)

Room 118, Carson City, Nevada 89710

C

KEVIN AGAN LAND & SHOREZONE CONSULTANT  
PO BOX 171  
TAHOE CITY CA 96145

| | \_ | \_ \_ \_ | | \_ \_ \_ \_ \_ | | \_ | \_ \_ | \_ | \_ | \_ \_ | \_ | \_ | 1

C

ROBERT MARTINI

1655 PINE CONE CIRCLE

INCLINE VILLAGE NV 89450

| | \_ \_ | \_ | \_ | \_ \_ \_ | \_ \_ | \_ | \_ | \_ | | \_ \_ \_ \_ | \_ \_ | | 2

C

EDWARD HORGAN

1665 PINE CONE CIRCLE

INCLINE VILLAGE NV 89450

| | \_ \_ | \_ | \_ | \_ \_ \_ | \_ \_ | \_ | \_ | \_ | | \_ \_ \_ \_ | \_ \_ | | 3

C

JIM LAWRENCE  
TAHOE REGIONAL PLANNING AGENCY  
PO BOX 1038  
ZEPHYR COVE NV 89448-1038  
**Error! 4**

C

RON PACHECO  
NEVADA DIVISION OF STATE LANDS  
333 WEST NYE LANE ROOM 118  
CARSON CITY NV 89710

| | \_ \_ | \_ | \_ | \_ \_ | \_ \_ \_ | \_ \_ \_ | | | | \_ \_ \_ \_ | \_ | \_ | 5

September 6, 2001

Regulatory Branch (200125037)(FGP)

Tom Gonzales  
P.O. Box 8486  
Incline Village, Nevada 89452

Dear Mr. Gonzales:

We have reviewed your application for a Department of the Army permit to rebuild the Tom Gonzales Pier. This project is located at 1675 Pine Cone Circle Lot 18, Incline Village, Nevada, County Assessor's Parcel Number 130-241-41. Your project may be constructed under the authority of our General Permit 16 for construction, modification and repair work in the Lake Tahoe Basin, provided the work does not deviate from your drawing(s), dated August 28, 2001, and complies with the enclosed conditions of General Permit Number 16 and your state and local permits.

Number 200125037 has been assigned to your file. This verification is valid for a period of two years from the date of this letter. You should contact this office if work will extend beyond this date.

If you have any questions concerning this general permit, please write to our Nevada Field Office, C. Clifton Young Federal Building, 300 Booth Street, Room 2103, Reno, Nevada 89509 or telephone (775) 784-5304.



Sincerely,

(b) (6)  
Chief, Nevada Regulatory Office

Enclosures:

Copies Furnished: w/o enclosures

(b) (6)  
Tahoe Regional Planning Agency, P.O. Box 1038, Zephyr Cove, Nevada 89448-1038  
U.S. Fish and Wildlife Service, Reno Fish and Wildlife Office, 1340 Financial Boulevard, Suite  
234, Reno, Nevada 89502  
Nevada Division of Environmental Protection, Attention: Rob Saunders, 333 W. Nye Lane, Carson  
City, Nevada 89706

(b) (6) [Redacted]

[Redacted]

[Redacted]

**Tahoe Regional Planning Agency  
P.O. Box 1038  
Zephyr Cove, Nevada 89448-1038**

**U.S. Fish and Wildlife Service  
Reno Fish and Wildlife Office  
1340 Financial Boulevard  
Suite 234  
Reno, Nevada 89502**

**Nevada Division of Environmental Protection  
Attention: Rob Saunders  
333 W. Nye Lane  
Carson City, Nevada 89706**

**Tom Gonzales  
P.O. Box 8486  
Incline Village, Nevada 89452**



**DEPARTMENT OF THE ARMY**  
**U.S. ARMY ENGINEER DISTRICT, SACRAMENTO**  
**CORPS OF ENGINEERS**  
**1325 J STREET**  
**SACRAMENTO CA 95814-2922**

REPLY TO  
ATTENTION OF

December 16, 2010

Regulatory Division (SPK-1995-00724-NO)

Manuel and Juanita Del Arroz  
P.O. Box 893  
Diablo, California 94528

Dear Mr. & Mrs. Del Arroz:

We are responding to your consultant's request for a determination of an After-The-Fact permit for the following existing structures: one Pier, two boatlifts, and four buoys located on Lake Tahoe. This project is located at 1655 and 1665 Pine Cone Circle, lakeward of Washoe Assessor's Parcel Numbers 130-241-39 and 130-241-40, in Section 23, Township 16 North, Range 18 East, Washoe County, Nevada.

The Sacramento District has issued General Permit 16 (GP16) for minimal impact activities in the Lake Tahoe Basin. On September 1, 1995, the Corps issued a Grandfather letter for two existing buoys on parcel 130-241-39. Then on November 12, 1996, the Corps issued GP16 for the Pier Modification/Boatlift project therefore the pier and boatlifts are already authorized under that GP16 authorization and the two buoys are authorized as Grandfathered structures. Based on the information your consultant has provided, regarding the remaining two existing buoys, on parcel 130-241-40, your project is authorized by this permit provided it complies with the enclosed information sheets and the following special condition:

1. All terms and conditions of the Tahoe Regional Planning Agency and Nevada Division of State Lands permits are expressly incorporated as Conditions of this permit.

In addition, we have received additional information and this letter serves as acknowledgement that we have updated our records to show that you are the current owner of the subject property and will assume responsibility for maintenance of the approved facilities.

We appreciate your feedback. At your earliest convenience, please tell us how we are doing by completing the customer survey on our website under *Customer Service Survey*.

Please refer to identification number SPK-1995-00724-NO in any correspondence concerning this project. If you have any questions, please contact (b) (6) at our Reno Field Office, 300 Booth Street, Room 3060, Reno, Nevada 89509, email (b) (6) @usace.army.mil, or telephone 775-784-5304. You may also use our website: [www.spk.usace.army.mil/regulatory.html](http://www.spk.usace.army.mil/regulatory.html).

Sincerely,

(b) (6)  
Senior Project Manager  
Reno Regulatory Office

Enclosure(s):

Copy furnished w/o Enclosure(s):

Tahoe Regional Planning Agency, P.O. Box 5310, Stateline, Nevada 89449-5310  
Elyse Randles, Nevada Division of State Lands, 901 South Stewart Street, Suite 5003, Carson  
City, Nevada 89701-5246  
Kevin Agan, Agan Consulting, Incorporated, P.O. Box 9180, Incline Village, Nevada 89450





DEPARTMENT OF THE ARMY  
U.S. ARMY ENGINEER DISTRICT, SACRAMENTO  
CORPS OF ENGINEERS  
1325 J STREET  
SACRAMENTO CA 95814-2922

REPLY TO  
ATTENTION OF

April 13, 2012

Regulatory Division (SPK-2005-00180-NO)

Matt White  
Incline Beach Association  
P.O. Box 9222  
Incline Village, Nevada 89450-9222

Dear Mr. White:

We are responding to your consultant's request for a Department of the Army permit for the Incline Beach Association Buoy Field project. This approximately 0.45-acre project involves activities, including discharges of dredged or fill material, in waters of the United States to retain 11 existing buoys and to place install 9 new buoys for a total of 20 buoys. The project is located in Lake Tahoe, Section 23, Township 16 North, Range 18 East, Mount Diablo Meridian, Latitude 39.233699°, Longitude -119.935916°, Incline Village, Washoe County, Nevada.

Based on the information your consultant has provided, the proposed activity, is authorized by Nationwide Permit Number 10 *Mooring Buoys*. Your work must comply with the general terms and conditions listed on the enclosed Nationwide Permit information sheets and the following special condition:

Special Condition

1. If you discover any previously unknown historic or archeological remains while accomplishing the activity authorized by this permit, you shall immediately notify the Corps of what you have found. The Corps will initiate the Federal and state coordination required to determine if the remains warrant a recovery effort or if the site is eligible for listing in the National Register of Historic Places.

You must sign the enclosed Compliance Certification and return it to this office within 30 days after completion of the authorized work.

This verification is valid for two years or until the NWP is modified, reissued, or revoked, whichever comes first. All of the existing NWPs are scheduled to be modified, reissued, or revoked on March 18, 2017. It is incumbent upon you to remain informed of changes to the NWPs. We will issue a public notice when the NWPs are reissued. Furthermore, if you commence or are under contract to commence this activity before the date that the relevant NWP is modified or revoked, you will have twelve (12) months from the date of the modification or revocation of the NWP to complete the activity under the present terms and conditions of this nationwide permit.

We appreciate your feedback. At your earliest convenience, please tell us how we are doing by completing the customer survey on our website under *Customer Service Survey*.

Please refer to identification number SPK-2005-00180-NO in any correspondence concerning this project. If you have any questions, please contact (b) (6) at our Reno Regulatory Field Office, 300 Booth Street, Room 3050, Reno, Nevada 89509, email (b) (6) @usace.army.mil, or telephone 775-784-5304. For more information regarding our program, please visit our website at [www.spk.usace.army.mil/regulatory.html](http://www.spk.usace.army.mil/regulatory.html).

Sincerely,

(b) (6)  
Senior Project Manager  
Reno Regulatory Field Office

Enclosures

Copies Furnished without enclosures

Tahoe Regional Planning Agency, P.O. Box 5310, Stateline, Nevada 89449-5310  
Elyse Randles, Nevada Division of State Lands, 901 S. Stewart Street, Suite 5003, Carson City,  
Nevada 89701-5249  
Susan Simon, Simon Environmental Planning, P.O. Box 9462, South Lake Tahoe, California  
96158

# COMPLIANCE CERTIFICATION

**Permit File Number:** SPK-2005-00180-NO

**Nationwide Permit Number:** 10 *Mooring Buoys*

**Permittee:** Matt White  
Incline Beach Association  
P.O. Box 9222  
Incline Village, Nevada 89450-9222

**County:** Washoe

**Date of Verification:** April 13, 2012

Within 30 days after completion of the activity authorized by this permit, sign this certification and return it to the following address:

U.S. Army Corps of Engineers  
Sacramento District  
Reno Regulatory Field Office  
300 Booth Street, Room 3050  
Reno, NV 89509  
FAX: 775-784-5306

*DLL-CESPK-RD-Compliance@usace.army.mil*

Please note that your permitted activity is subject to a compliance inspection by a U.S. Army Corps of Engineers representative. If you fail to comply with the terms and conditions of the permit your authorization may be suspended, modified, or revoked. If you have any questions about this certification, please contact the Corps of Engineers.

\* \* \* \* \*

*I hereby certify that the work authorized by the above-referenced permit, including all the required mitigation, was completed in accordance with the terms and conditions of the permit verification.*

\_\_\_\_\_  
Signature of Permittee

\_\_\_\_\_  
Date

**APPROVED JURISDICTIONAL DETERMINATION FORM**  
**U.S. Army Corps of Engineers**

**SECTION I: BACKGROUND INFORMATION**

**A. REPORT COMPLETION DATE FOR APPROVED JURISDICTIONAL DETERMINATION (JD):** 4-16-12.

**B. DISTRICT OFFICE, FILE NAME, AND NUMBER:** Sacramento District, , SPK-2005-00180.  
Name of water being evaluated on this JD form: Lake Tahoe

**C. PROJECT LOCATION AND BACKGROUND INFORMATION:**

State: NV County: Washoe City: Incline Village

Center coordinates of site (lat/long in degree decimal format): Lat: 39.2337° N, Long: -119.93592° W

Universal Transverse Mercator: \_\_\_\_\_.

Name of nearest waterbody: Lake Tahoe.

Name of nearest Traditional Navigable Water (TNW) into which the aquatic resource flows: Lake Tahoe.

Name of watershed or Hydrologic Unit Code (HUC): Lake Tahoe, California, Nevada., 16050101.

Check if map/diagram of review area and/or potential jurisdictional areas is/are available upon request.

Check if other sites (e.g., offsite mitigation sites, disposal sites, etc.) are associated with this action and are recorded on a different JD form. List other JDs: \_\_\_\_\_

**D. REVIEW PERFORMED FOR SITE EVALUATION (CHECK ALL THAT APPLY):**

Office (Desk) Determination. Date: 4-16-12.

Field Determination. Date(s): \_\_\_\_\_.

**SECTION II: SUMMARY OF FINDINGS**

**A. RHA SECTION 10 DETERMINATION OF JURISDICTION.**

There **Are** "*navigable waters of the U.S.*" within Rivers and Harbors Act (RHA) jurisdiction (as defined by 33 CFR part 329) in the review area. [*Required*]

Waters subject to the ebb and flow of the tide.

Waters are presently used, or have been used in the past, or may be susceptible for use to transport interstate or foreign commerce.

Explain: Lake Tahoe is an interstate water that has had past commerce as well as present commerce and may be susceptible for use in interstate commerce in the future.

**B. CWA SECTION 404 DETERMINATION OF JURISDICTION.**

There **Are** "*waters of the U.S.*" within Clean Water Act (CWA) jurisdiction (as defined by 33 CFR part 328) in the review area. [*Required*]

**1. Waters of the U.S.**

**a. Indicate presence of waters of U.S. in review area (check all that apply):<sup>1</sup>**

TNWs, including territorial seas

Wetlands adjacent to TNWs

Relatively permanent waters<sup>2</sup> (RPWs) that flow directly or indirectly into TNWs

Non-RPWs that flow directly or indirectly into TNWs

Wetlands directly abutting RPWs that flow directly or indirectly into TNWs

Wetlands adjacent to but not directly abutting RPWs that flow directly or indirectly into TNWs

Wetlands adjacent to non-RPWs that flow directly or indirectly into TNWs

Impoundments of jurisdictional waters

Isolated (interstate or intrastate) waters, including isolated wetlands

**b. Identify (estimate) size of waters of the U.S. in the review area:**

Non-wetland waters: \_\_\_\_\_ linear feet \_\_\_\_\_ width (ft) and/or 0.45 acres.

Wetlands: \_\_\_\_\_ acres.

**c. Limits (boundaries) of jurisdiction based on: **Established by OHWM** and **Pick List****

Elevation of established OHWM (if known): 6229.1 ft.

**2. Non-regulated waters/wetlands (check if applicable):<sup>3</sup>**

Potentially jurisdictional waters and/or wetlands were assessed within the review area and determined to be not jurisdictional.

Explain: \_\_\_\_\_.

<sup>1</sup> Boxes checked below shall be supported by completing the appropriate sections in Section III below.

<sup>2</sup> For purposes of this form, an RPW is defined as a tributary that is not a TNW and that typically flows year-round or has continuous flow at least "seasonally" (e.g., typically 3 months).

<sup>3</sup> Supporting documentation is presented in Section III.F.

**SECTION III: CWA ANALYSIS**

**A. TNWs AND WETLANDS ADJACENT TO TNWs**

**1. TNW**

**Identify TNW:** Lake Tahoe.

Summarize rationale supporting determination: Lake Tahoe is a Section 10 Navigable water of the U.S.

**2. Wetland adjacent to TNW**

Summarize rationale supporting conclusion that wetland is “adjacent”: \_\_\_\_\_.

**B. CHARACTERISTICS OF TRIBUTARY (THAT IS NOT A TNW) AND ITS ADJACENT WETLANDS - Not applicable**

**C. SIGNIFICANT NEXUS DETERMINATION - Not applicable**

**D. DETERMINATIONS OF JURISDICTIONAL FINDINGS. THE SUBJECT WATERS/WETLANDS ARE:**

**1. TNWs and Adjacent Wetlands.** Check all that apply and provide size estimates in review area:

- TNWs: \_\_\_\_\_ linear feet \_\_\_\_\_ width (ft), or 0.45 acres.
- Wetlands adjacent to TNWs: \_\_\_\_\_ acres.

**E. ISOLATED [INTERSTATE OR INTRA-STATE] WATERS, INCLUDING ISOLATED WETLANDS, THE USE, DEGRADATION OR DESTRUCTION OF WHICH COULD AFFECT INTERSTATE COMMERCE, INCLUDING ANY SUCH WATERS – NOT APPLICABLE**

**F. NON-JURISDICTIONAL WATERS, INCLUDING WETLANDS (CHECK ALL THAT APPLY): Not applicable**

**SECTION IV: DATA SOURCES.**

**A. SUPPORTING DATA. Data reviewed for JD:**

- Maps, plans, plots or plat submitted by or on behalf of the applicant/consultant: \_\_\_\_\_.
- Data sheets prepared/submitted by or on behalf of the applicant/consultant.
  - Office concurs with data sheets/delineation report.
  - Office does not concur with data sheets/delineation report.
- Data sheets prepared by the Corps: \_\_\_\_\_.
- Corps navigable waters’ study: The waterbody is on the Section 10 Navigable Waterway List for Sacramento District.
- U.S. Geological Survey Hydrologic Atlas: \_\_\_\_\_.
  - USGS NHD data.
  - USGS 8 and 12 digit HUC maps.
- U.S. Geological Survey map(s). Cite scale & quad name: 1:24K; CA-KINGS BEACH
- USDA Natural Resources Conservation Service Soil Survey. Citation: \_\_\_\_\_.
- National wetlands inventory map(s). Cite name: \_\_\_\_\_.
- State/Local wetland inventory map(s): \_\_\_\_\_
- FEMA/FIRM maps: \_\_\_\_\_.
- 100-year Floodplain Elevation is: \_\_\_\_\_ (National Geodectic Vertical Datum of 1929)
- Photographs:  Aerial (Name & Date): \_\_\_\_\_  
or  Other (Name & Date): \_\_\_\_\_.
- Previous determination(s). File no. and date of response letter: \_\_\_\_\_.
- Applicable/supporting case law: \_\_\_\_\_.
- Applicable/supporting scientific literature: \_\_\_\_\_.
- Other information (please specify): \_\_\_\_\_.

**B. ADDITIONAL COMMENTS TO SUPPORT JD: Lake Tahoe is a Section 10 Navigable Water of the U.S.**

**REGULATORY IDENTIFICATION NUMBER**

199500724

November 12, 1996

Regulatory Branch (199500724) 3296 GP-16

Kevin Agan Land & Shorezone Consultant  
P.O. Box 171  
Tahoe City, California 96145

Dear Mr. Agan:

We have reviewed the application submitted on behalf of Robert Martini and Edward Horgan for a Department of the Army permit to modify and existing pierhead on a 135-foot pier and install two boatlifts. This project is located in Lake Tahoe at Mile 60.20, Washoe County Assessor's Parcel Number 130-241-39 & 40 at 1655 & 1665 Pine Cone Circle, Incline Village, Nevada. Your project may be constructed under the authority of our General Permit 16 for construction, modification and repair work in the Lake Tahoe Basin, provided the work does not deviate from your drawings, dated January, 1996, and complies with the enclosed conditions of General Permit Number 16 and your state and local permits.

Number 199500724 has been assigned to your file. This verification is valid for a period of two years from the date of this letter. You should contact this office if work will extend beyond this date.

If you have any questions concerning this general permit, please write to (b) (6), Room 1480, at the letterhead address, or telephone (916) 557-7772.

Sincerely,

(b) (6)  
Chief, Nevada Office

Enclosure

Copies Furnished: with enclosure

Robert Martini, 1655 Pine Cone Circle,  
Incline Village, Nevada 89450  
Edward Horgan, 1665 Pine Cone Circle,  
Incline Village, Nevada 89450  
Jim Lawrence, Tahoe Regional Planning Agency, P.O. Box 1038,  
Zephyr Cove, Nevada 89448-1038  
Ron Pacheco, Nevada Division of State Lands, 333 West Nye Lane,  
Room 118, Carson City, Nevada 89710

**KEVIN M. AGAN**  
**LAND & SHOREZONE CONSULTANT**

November 6, 1996

(b) (6)

U.S. Army Corps of Engineers  
1325 "J" Street, Room 1480  
Sacramento, CA 95814

**Subject: Pier Modification/Boatlifts - Martini/Horgan Properties  
Washoe County APN: 130-241-39, 40**

Dear (b) (6),

Per our telephone conversation, please find attached for your review copies of the Tahoe Regional Planning Agency Permit; Nevada Division of State Lands Permit; project narrative; construction method; and exhibit drawings for the above referenced project. As discussed, this project should now meet the Corps General Permit No. 16 (GP-016) requirements and the retainment of the existing mooring buoys have already received "grandfather" status from your agency per the attached September 1, 1995 Corps letter.

Consequently, please provide me the formal Corps approval for the proposed project at your earliest convenience. Should you have any questions or need to discuss this matter in greater detail, please feel free to give me a call.

Sincerely yours,

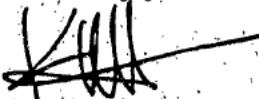
  
Kevin M. Agan  
Principal

KMA:  
Attachments



**TAHOE REGIONAL PLANNING AGENCY**

308 Dorla Court  
Elks Point, Nevada

P.O. Box 1038  
Zephyr Cove, Nevada 89448-1038

(702) 588-4547  
Fax (702) 588-4527  
Email: trpa@sierra.net

PERMIT

PROJECT DESCRIPTION: Martini/Horgan Pier Expansion APN 130-241-39  
PERMITTEE(S): Robert E. Martini and Edward J. Horgan FILE #950801  
COUNTY/LOCATION: Washoe/1655 and 1665 Pine Cone Circle, Incline Village, NV

Having made the findings required by Agency ordinances and rules, TRPA approved the project on September 25, 1996, subject to the standard conditions of approval attached hereto (Attachment S) and the special conditions found in this permit.

This permit shall expire on September 25, 1999, without further notice unless the construction has commenced prior to this date and diligently pursued thereafter. Commencement of construction consists of pouring concrete for a foundation and does not include grading, installation of utilities or landscaping. Diligent pursuit is defined as completion of the project within the approved construction schedule. The expiration date shall not be extended unless the project is determined by TRPA to be the subject of legal action which delayed or rendered impossible the diligent pursuit of the permit.

NO CONSTRUCTION OR GRADING SHALL COMMENCE UNTIL THE PERMITTEE OBTAINS A COUNTY BUILDING PERMIT. THE COUNTY PERMIT AND THE TRPA PERMIT ARE INDEPENDENT OF EACH OTHER AND MAY HAVE DIFFERENT EXPIRATION DATES AND RULES REGARDING EXTENSIONS. NO CONSTRUCTION OR GRADING SHALL COMMENCE UNTIL ALL PRE-CONSTRUCTION CONDITIONS OF APPROVAL ARE SATISFIED AS EVIDENCED BY TRPA'S ACKNOWLEDGMENT OF THIS PERMIT. IN ADDITION, NO CONSTRUCTION OR GRADING SHALL COMMENCE UNTIL TRPA RECEIVES A COPY OF THIS PERMIT UPON WHICH THE PERMITTEE(S) HAS ACKNOWLEDGED RECEIPT OF THE PERMIT AND ACCEPTANCE OF THE CONTENTS OF THE PERMIT AND A TRPA PREGRADING INSPECTION HAS BEEN CONDUCTED. TRPA'S ACKNOWLEDGMENT IS NECESSARY TO OBTAIN A COUNTY BUILDING PERMIT.

L. Burns \_\_\_\_\_ Date 9-27-96  
TRPA Executive Director/Designee

\*\*\*\*\*  
PERMITTEE'S ACCEPTANCE: I have read the permit and the conditions of approval and understand and accept them. I also understand that I am responsible for compliance with all the conditions of the permit and am responsible for my agents' and employees' compliance with the permit conditions. I also understand that if the property is sold, I remain liable for the permit conditions until or unless the new owner acknowledges the transfer of the permit and notifies TRPA in writing of such acceptance. I also understand that certain mitigation fees associated with this permit are non-refundable once paid to TRPA. I understand that it is my sole responsibility to obtain any and all required approvals from any other state, local or federal agencies that may have jurisdiction over this project whether or not they are listed in this permit.

Signature of Permittee(s) \_\_\_\_\_ Date \_\_\_\_\_  
\*\*\*\*\*  
LB/jm PERMIT CONTINUED ON NEXT PAGE

APN 130-241-39,40  
File No. 950801

Excess Coverage Mitigation Fee: Amount \$\*\_ Paid \_\_\_\_\_ Receipt No. \_\_\_\_\_

Shorezone Mitigation Fee: Amount \$500 Paid \_\_\_\_\_ Receipt No. \_\_\_\_\_

Security Posted: Amount \$\*\_ Posted \_\_\_\_\_ Receipt No. \_\_\_\_\_ Type \_\_\_\_\_

Security Administrative Fee: Amount \$\*\* Paid \_\_\_\_\_ Receipt No. \_\_\_\_\_

\* To be determined.

\*\* \$110 if cash security posted.

Required plans determined to be in conformance with approval: Date \_\_\_\_\_

TRPA ACKNOWLEDGMENT: The permittee has complied with all pre-construction conditions of approval as of this date and is eligible for a county building permit:

\_\_\_\_\_  
TRPA Executive Director/Designee

\_\_\_\_\_  
Date

\*\*\*\*\*

SPECIAL CONDITIONS

This permit is for a pier expansion, including construction of a new catwalk, two boat lifts, and a new pier deck at elevation 6,223 feet. The length of the pier shall not extend beyond the TRPA pier head line. All pier components shall comply with the design requirements of Chapter 54, and other applicable chapters, of the TRPA Code.

1. Prior to commencement of construction the following special conditions of approval must be satisfied:

- A. The security required under Standard Condition A.3 of Attachment S shall be equal to 110 percent of the cost for all painting, landscaping to screen adjacent residences, and all required Best Management Practices (BMPs).
- B. The permittees shall mitigate excess land coverage in the project area by submitting an excess land coverage mitigation fee, or by removing coverage within Hydrologic Transfer Area Number 1, Incline (see attached map).

The excess coverage mitigation fee shall be calculated as follows:

- (1) Estimated Project Construction Cost (structural only) x 0.020

Please provide a construction cost estimate by your contractor, contractor, architect, or engineer

Excess land coverage may be removed in lieu of an excess coverage mitigation fee. To calculate the amount of excess coverage to be removed use the following formula:

- (2) Excess coverage mitigation fee (per formula (1), above) divided by \$5.00 per square foot.

If you choose this option, please revise your final site plan and land coverage calculations to account for the coverage removal.

- C. The permittees shall submit a shorezone mitigation fee of \$500 for the construction of new boat lifts on the pier.
- D. The applicants shall submit a construction schedule prior to commencement of construction. The schedule will identify dates for the following: when installation of temporary erosion control structures and turbidity screens will occur, when construction will start; when construction debris will be removed; when installation of all permanent erosion control structures will occur and when construction will be completed.
- E. The permittee shall submit final designs for the proposed boat lifts for TRPA review and approval. These boat lifts shall not extend more than 4 feet above the pier deck.
- F. The applicant shall submit 3 sets of final construction drawings and upland site plans to TRPA.
- G. The permittees shall record a deed restriction or other covenant running with the land permanently limiting pier development potential to one pier within the project area, and providing permanent access to the subject pier from APNs 130-241-39 and 130-241-40.
- H. The final colors and materials used for construction of the pier, catwalks, and boat lifts shall be approved by TRPA prior to construction. Please submit color samples to TRPA for review and approval.
- I. The permittee shall submit a final scenic mitigation plan to TRPA for review and approval. This plan shall incorporate additional vegetation screening of the Martini residence as viewed from Lake Tahoe, or darkening of the Martini residence roof.
- J. The permittees shall submit a Best Management Practices (BMP) plan to TRPA for review and approval. This plan shall include: paving of all unpaved driveways, infiltration of all stormwater runoff in accordance with the requirements of Attachment S (including but not limited to construction of new infiltration trenches for the Horgan house), stabilization of the eroding area adjacent to the pier, and construction of vehicle barriers at the edge of the driveway on the east side of the Horgan house.

- K. The permittees shall revise the site plan to eliminate the small section of driveway that passes through the center landscape area circle nearest to the Organs house. TRPA was unable to verify this area as having land coverage. Please adjust the land coverage calculation accordingly.
2. Spray painting and the use of tributyltin (TBT) is prohibited.
  3. Storage of construction materials shall be prohibited on the beach or within 50 feet of the beach bluff.
  4. Disturbance of the lake bed materials shall be kept to the minimum necessary for project construction.
  5. The discharge of petroleum products, construction waste and litter (including sawdust), or earthen materials to the surface waters of the Lake Tahoe Basin is prohibited. All surplus construction waste materials shall be removed from the project and deposited only at approved points of disposal.
  6. The use of wood preservatives on wood in contact with the water is prohibited and extreme care shall be taken to insure that wood preservatives are not introduced into Lake Tahoe.
  7. No containers of fuel, paint, or other hazardous materials may be stored on the pier.
  8. Gravel, cobble, or small boulders shall not be disturbed or removed to leave exposed sandy areas, before, during, or after construction.
  9. The applicant shall submit post-construction photos within 30 days of the project completion date, demonstrating any resultant impacts to scenic quality as viewed from 300 feet from shore looking landward and to lake bottom conditions as viewed from the subject parcel.
  10. Best practical control technology shall be employed to prevent earthen materials to be re-suspended as a result of pier construction and from being transported to adjacent lake water. If determined by the TRPA Compliance Officer to be necessary, the applicant shall install a turbidity screen around the entire construction site (in the water) prior to construction. This screen may be removed upon project completion only upon a satisfactory inspection by TRPA to insure that all suspended materials have settled.
  11. No trees or other plants shall be removed to provide foot or vehicular access to the pier during or after the project construction.

## TAHOE REGIONAL PLANNING AGENCY

308 Dorla Court  
Elks Point, Nevada

P.O. Box 1038  
Zephyr Cove, Nevada 89448-1038

(702) 588-4547  
Fax (702) 588-4527  
Email: trpa@sierra.net

### STATEMENT OF NO SIGNIFICANT EFFECT

PROJECT DESCRIPTION: Martini/Horgan Pier Expansion      APN: 130-241-39  
PERMITTEE(S): Robert E. Martini and Edward J. Horgan      FILE: #960801  
COUNTY/LOCATION: Washoe/1655 and 1665 Pine Cone Circle, Incline Village, NV

Staff Analysis: In accordance with Article VI of the Tahoe Regional Planning Compact, as amended, and Section 6.3 of the TRPA Rules and Regulations of Practice and Procedure, the TRPA staff has reviewed the information submitted with the subject project. On the basis of this initial environmental evaluation, Agency staff has found that the subject project will not have a significant effect on the environment.

Determination: Based on the above-stated finding, the subject project is conditionally exempt from the requirement to prepare an Environmental Impact Statement. The conditions of this exemption are the conditions of permit approval.

Lyne Barnum  
TRPA Chairman or Executive Director/Designee

9-27-96  
Date

PERMIT NUMBER L0461

STATE OF NEVADA  
DEPARTMENT OF CONSERVATION AND NATURAL RESOURCES  
DIVISION OF STATE LANDS  
333 West Nye Lane, Room 118  
Carson City, Nevada 89710

THE STATE OF NEVADA, acting through the Division of State Lands pursuant to NRS 321.595 and NRS 322.100 does hereby grant a permit to:

Name: ROBERT E. MARTINI, EDWARD J. HORGAN AND THERESA HORGAN  
C/O KEVIN AGAN

Mailing Address: P.O. BOX 171  
TAHOE CITY, CALIFORNIA 96145

1. The physical address in which this facility is to be located is: \_\_\_\_\_  
1665 PINE CONE CIRCLE  
INCLINE VILLAGE, NEVADA

Parcel Number: 130-241-40 County: WASHOE  
SEC: 23 TWP: 16 NORTH RGE: 18 EAST

2. Permittee is authorized: TO RETAIN AND REPAIR ONE (1) EXISTING MULTIPLE USE PIER  
AND ADD TWO (2) BOAT HOISTS. ADD A CATWALK AND STEEL STEPS. THE STEEL STEPS  
SHOULDN'T EXTEND BEYOND ELEVATION 6223.0 FEET. THIS PERMIT ABROGATES STATE  
LANDS PERMIT NUMBER L0149.

3. Proof of financial responsibility in amount of: \$1,000,000.00  
has been established in the following manner: \_\_\_\_\_  
SAFECO INSURANCE COMPANY POLICY NUMBER 0S566092

4. Conditions for permit approval: SEE ATTACHED CONDITIONS

5. A permit given by the Division of State Lands does not give any property rights either in real estate or material nor does it obviate the necessity of obtaining federal, local or regional assent to the work authorized.  
6. The public shall not be denied reasonable access to or the use of any State lands or facilities permitted herein.

PERMIT TERM: TWENTY (20) YEARS; beginning: JULY 1, 1995;  
ending: JUNE 30, 2015; unless sooner terminated as provided.

ANNUAL FEE RATE: 1995 - \$400.00 FEE AS OF JULY 1, 1996 - \$62.50

Given under the hand of the Administrator of the Division of State Lands

this 5TH day of JANUARY 1996.



PAMELA B. WILCOX  
Administrator  
Division of State Lands  
PAMELA B. WILCOX

PETER G. MORROS  
*Director*  
Department of Conservation  
and Natural Resources

PAMELA B. WILCOX  
*Administrator*

BOB MILLER  
*Governor*



State Land Office  
State Land Use Planning Agency  
*Address Reply to*  
Division of State Lands  
Capitol Complex  
Carson City, Nevada 89710  
(702) 687-4363

STATE OF NEVADA

DEPARTMENT OF CONSERVATION AND NATURAL RESOURCES

## Division of State Lands

### ROBERT E. MARTINI, EDWARD J. HORGAN AND THERESA HORGAN MULTIPLE-USE PIER AND BOAT HOIST PERMIT NUMBER LO461 CONDITIONS

1. This permit is subject to the acquisition of all local, regional, state and federal permits and approvals including, but not limited to, Tahoe Regional Planning Agency and U.S. Army Corps of Engineers permits and approvals.
2. The multiple-use pier and low level boat hoists must be constructed according to the attached approved plans.
3. No rocks or other material may be moved or relocated at or around the site of the pier and boat hoists.
4. The pier and boat hoists must be maintained in good repair at all times.
5. At no time will the permittees deny general public access to the waters of Lake Tahoe in, under and around the pier or other structures for fishing or other recreational uses.
6. The permittees understand and agree that the insurance coverage must remain in effect at all times. If the insurance coverage is allowed to expire, the permittees will be required to immediately remove the pier and boat hoists from Lake Tahoe.
7. A permit from the Division of State Lands is required prior to commencement of any future changes, relocation or expansion of the pier and/or boat hoists as approved under this permit.
8. No mooring buoys are permitted or allowed under this permit.
9. The permittees, their successors and assigns, understand and agree that the Division of State Lands is required, pursuant to NRS 322.120, to assess annual permit fees in the amount of SIXTY-TWO DOLLARS AND FIFTY CENTS (\$62.50) for one (1) existing multiple use pier in Lake Tahoe below elevation 6223.0 feet. No fee is assessed for the boat hoists. Said fees to be paid on or before July 1, 1996.
10. Failure to concur with or comply with any of the conditions contained herein will cause this permit to become invalid and require the immediate removal of the pier and boat hoists from Lake Tahoe.
11. This permit abrogates permit LO149.

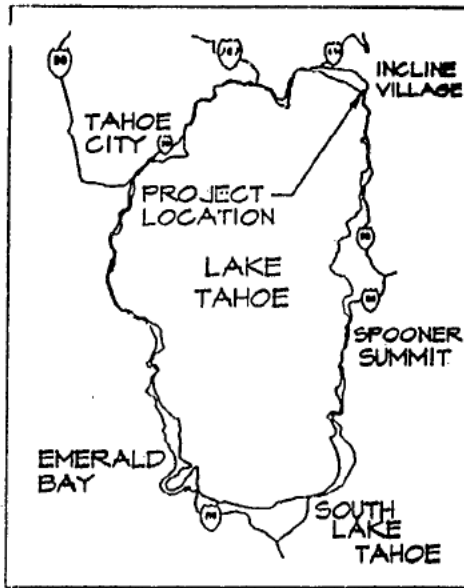
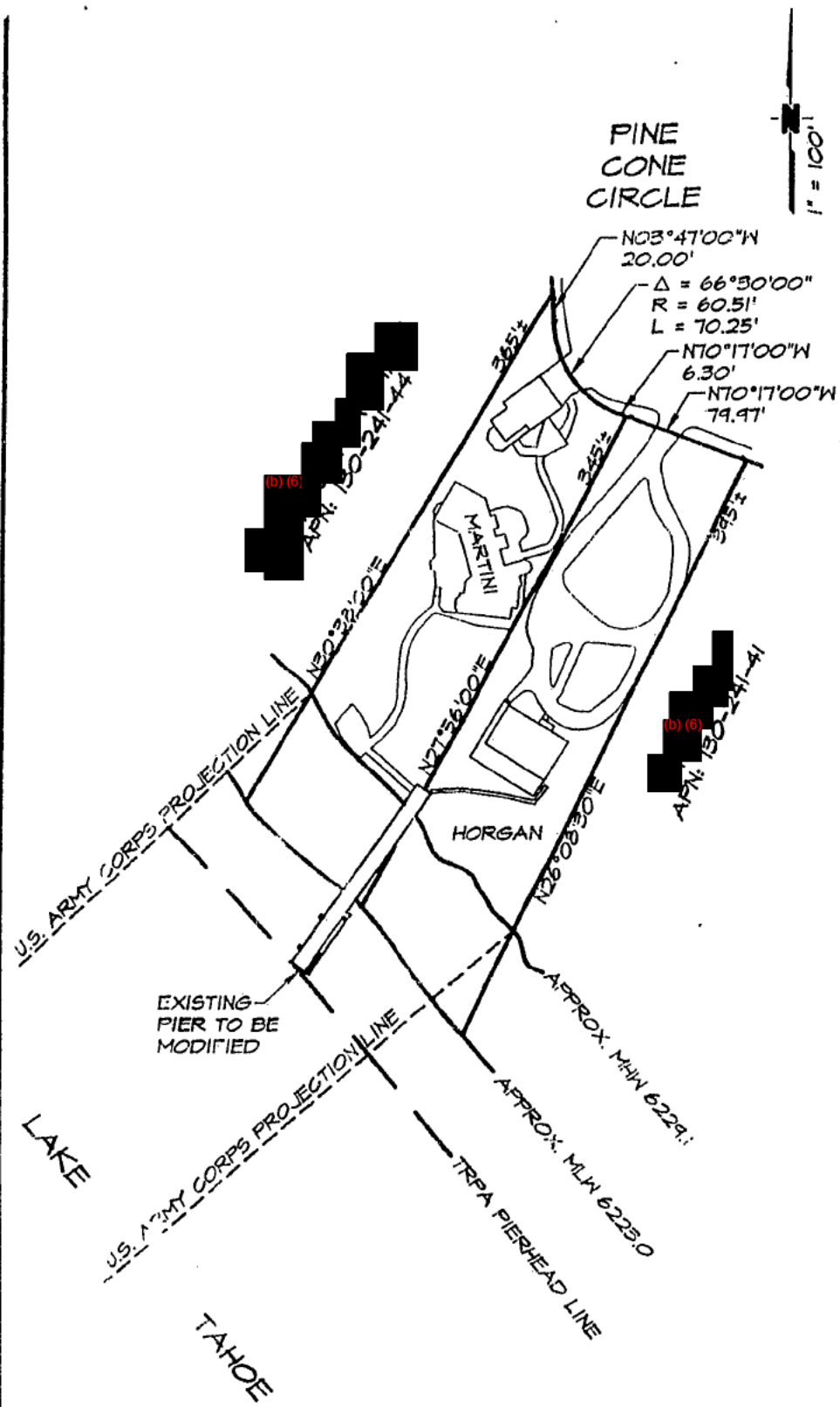

VICINITY MAP  
NO SCALE

**NOTES**

1) THE PROJECT INVOLVES THE MODIFICATION OF THE EXISTING MULTIPLE-USE PIERHEAD. THIS MODIFICATION INVOLVES RAISING THE PIER DECK, THE INSTALLATION OF A CATWALK, AND THE INSTALLATION OF TWO BOATLIFTS.

**MARTINI/HORGAN PIER MODIFICATION AND BOATLIFTS**  
 1655/1665 PINE CONE CIRCLE, INCLINE VILLAGE, NEVADA  
 WASHOE COUNTY, APN: 130-241-39,40

THIS DRAWING IS FOR PERMIT PURPOSES ONLY



**KEVIN M. AGAN**  
 Land & Shorezone Consultant  
 Post Office Box 171  
 Tahoe City, California 96145  
 916.581.1640 Fax 916.581.1641

JANUARY 1996

SHEET 1 OF 2



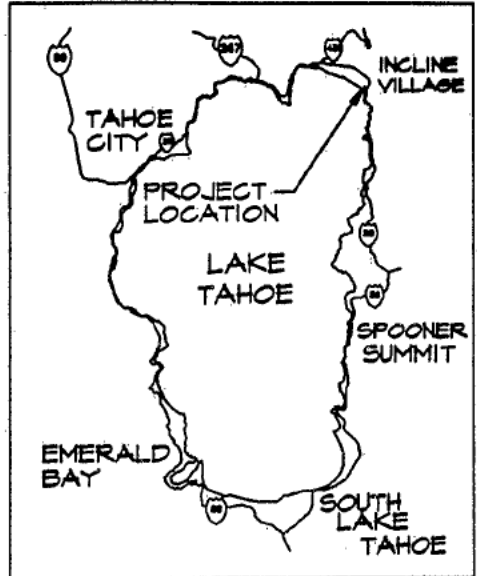
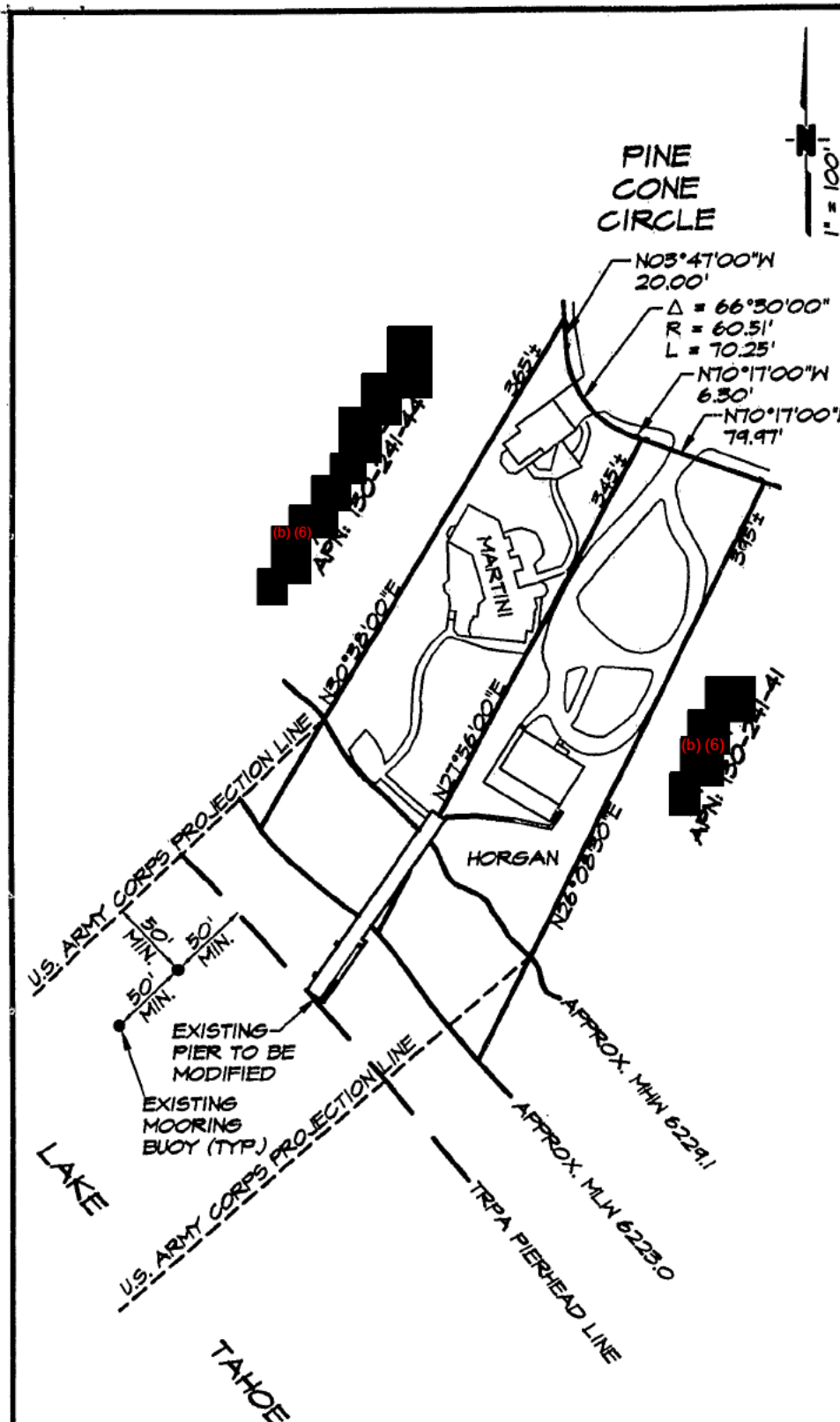

VICINITY MAP  
NO SCALE

NOTES

- 1) THE PROJECT INVOLVES THE MODIFICATION OF THE EXISTING MULTIPLE-USE PIERHEAD. THIS MODIFICATION INVOLVES RAISING THE PIER DECK, THE INSTALLATION OF A CATWALK, AND THE INSTALLATION OF TWO BOATLIFTS.
- 2) THE EXISTING BUOYS WILL BE CONVERTED TO SEASONAL USE. SEASONAL USE IS IDENTIFIED AS REMOVING THE BUOY FLOATS BETWEEN OCTOBER 15 AND MAY 15 OF EACH YEAR.

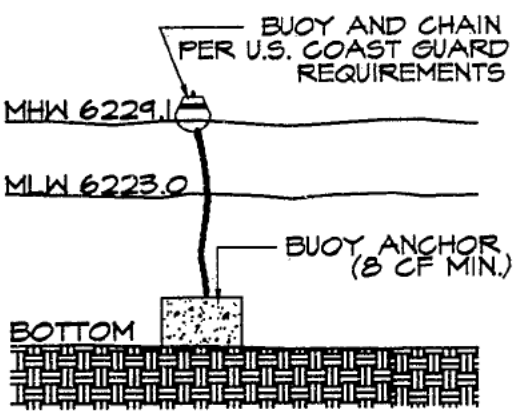

BUOY DETAIL  
NO SCALE

**MARTINI/HORGAN PIER MODIFICATION, BOATLIFTS, BUOYS**  
1635/1665 PINE CONE CIRCLE, INCLINE VILLAGE, NEVADA  
WASHOE COUNTY, APN: 130-241-39,40

THIS DRAWING IS FOR PERMIT PURPOSES ONLY



**KEVIN M. AGAN**  
Land & Shorezone Consultant  
Post Office Box 171  
Tahoe City, California 96145  
916.581.1640 Fax 916.581.1641

JANUARY 1996  
SHEET 1 OF 2

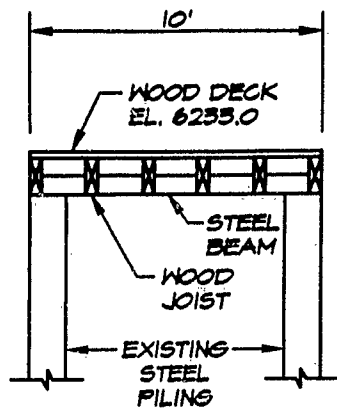

**WALKWAY SECTION**  
N.T.S.

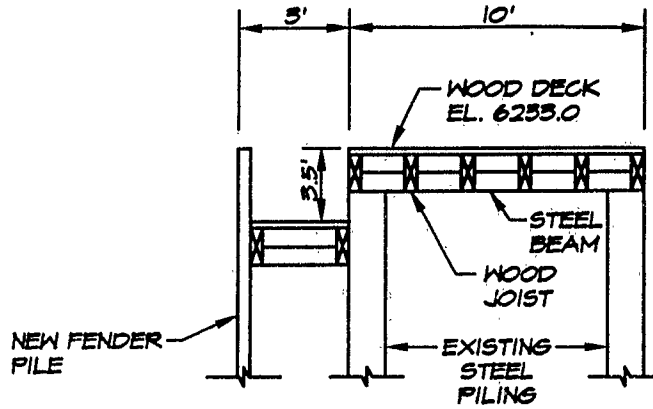

**PIERHEAD SECTION**  
N.T.S.

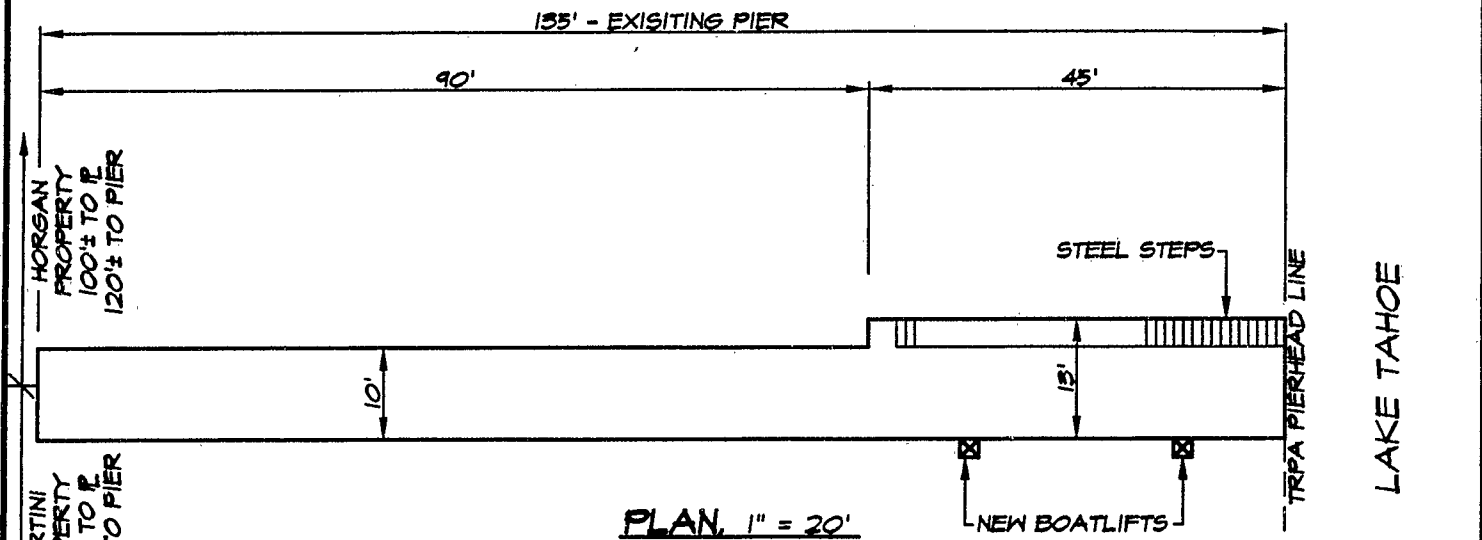

**PLAN, 1" = 20'**

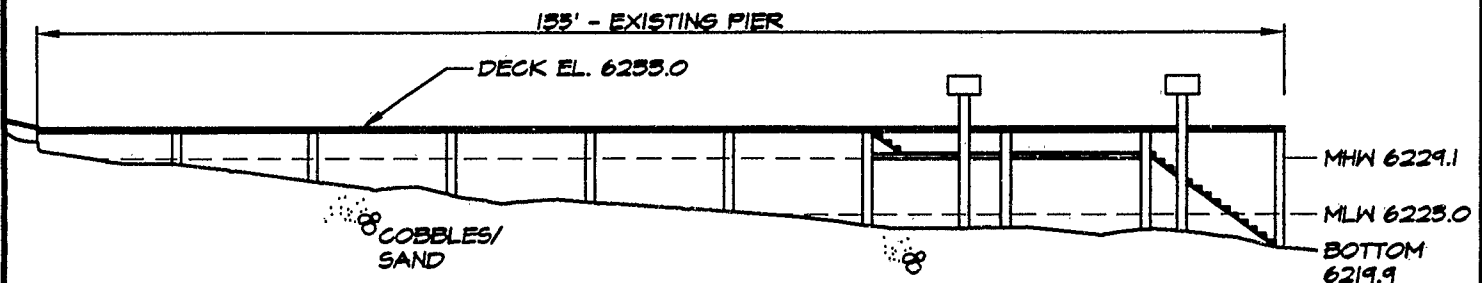

**PROFILE, 1" = 20'**

**MARTINI/HORGAN PIER MODIFICATION, BOATLIFTS, BUOYS**

1655/1665 PINE CONE CIRCLE, INCLINE VILLAGE, NEVADA  
WASHOE COUNTY, APN: 130-241-39,40

THIS DRAWING  
IS FOR PERMIT  
PURPOSES ONLY



**KEVIN M. AGAN**  
Land & Shorezone Consultant  
Post Office Box 171  
Tahoe City, California 96145  
916.581.1640 Fax 916.581.1641

JANUARY 1996

SHEET 2 OF 2

## **MARTINI/HORGAN PIER MODIFICATION WASHOE COUNTY APN: 130-241-39, 40**

### **Project Narrative**

The project consists of raising the entire pier deck and modifying the pierhead with a catwalk and steel steps down to the lake. No pile driving is proposed for the pier with the exception of two boatlift installations and fender piling along the outboard edge of the catwalk. The work includes replacing the steel beams, wood joists and decking of the affected portion of the pier. The application includes the multiple-use recognition of this structure between the two lakefront parcels. No shoreline or lakebottom disturbance is anticipated with this project. Please refer to the submittal drawings for the visual representation of the proposed project.

### **Construction Method**

The repair work is to be performed by a rubber barge (i.e. Larc, etc.) with pile driver. All the work is proposed to be performed above the lakebottom with the exception of the two boatlift installations and small fender piling along the outboard edge of the proposed catwalk. No vehicular traffic either by barge or other large equipment will occur landward of the low water mark of Lake Tahoe. Tarps and/or a small boat(s) will be placed underneath the work areas to prevent discharge of waste material from entering into the lake. All construction wastes will be collected and disposed at the nearest dumpster or sanitary landfill site. Should the lakebottom sediment be disturbed, the rock cobble will be hand placed into a random pattern to restore the lakebottom to a natural condition which existed prior to the construction activity.

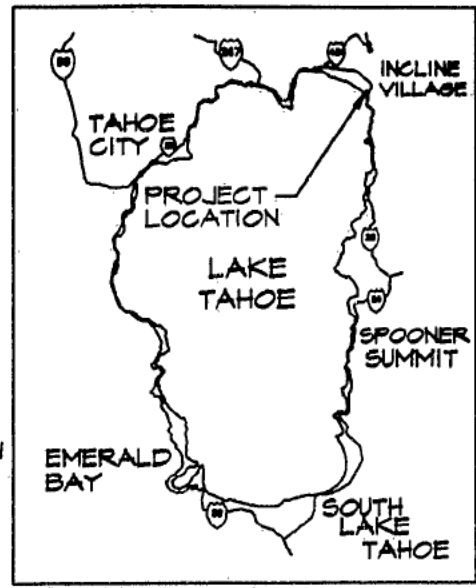
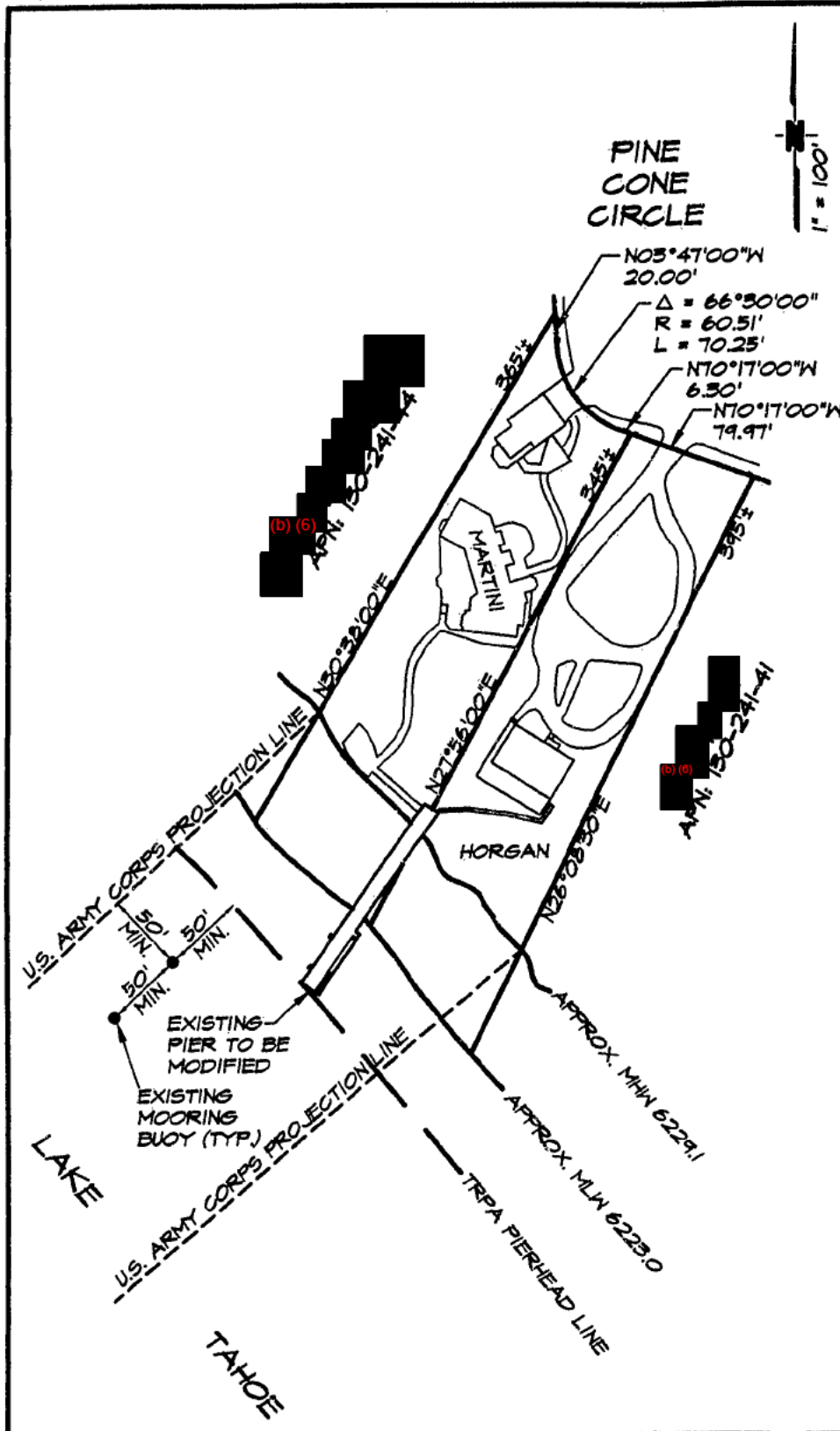

VICINITY MAP  
NO SCALE

NOTES

- 1) THE PROJECT INVOLVES THE MODIFICATION OF THE EXISTING MULTIPLE-USE PIERHEAD. THIS MODIFICATION INVOLVES RAISING THE PIER DECK, THE INSTALLATION OF A CATWALK, AND THE INSTALLATION OF TWO BOATLIFTS.
- 2) THE EXISTING BUOYS WILL BE CONVERTED TO SEASONAL USE. SEASONAL USE IS IDENTIFIED AS REMOVING THE BUOY FLOATS BETWEEN OCTOBER 15 AND MAY 15 OF EACH YEAR.

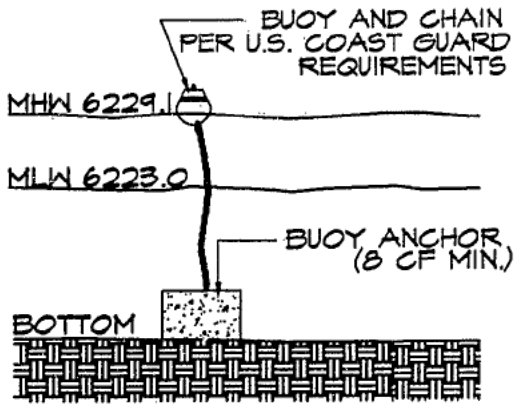

BUOY DETAIL  
NO SCALE

**MARTINI/HORGAN PIER MODIFICATION, BOATLIFTS, BUOYS**  
 1655/1665 PINE CONE CIRCLE, INCLINE VILLAGE, NEVADA  
 WASHOE COUNTY, APN: 130-241-39,40

THIS DRAWING IS FOR PERMIT PURPOSES ONLY



**KEVIN M. AGAN**  
 Land & Shorezone Consultant  
 Post Office Box 171  
 Tahoe City, California 96145  
 916.581.1640 Fax 916.581.1641

JANUARY 1996

SHEET 1 OF 2

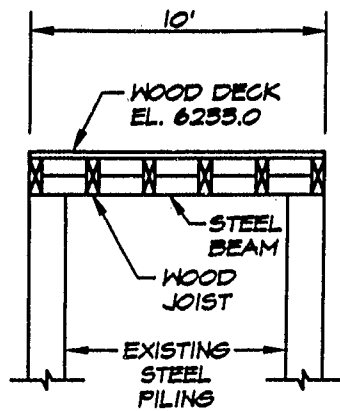

**WALKWAY SECTION**  
N.T.S.

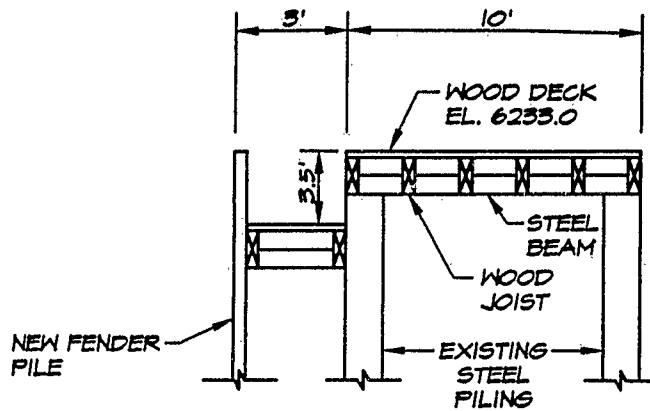

**PIERHEAD SECTION**  
N.T.S.

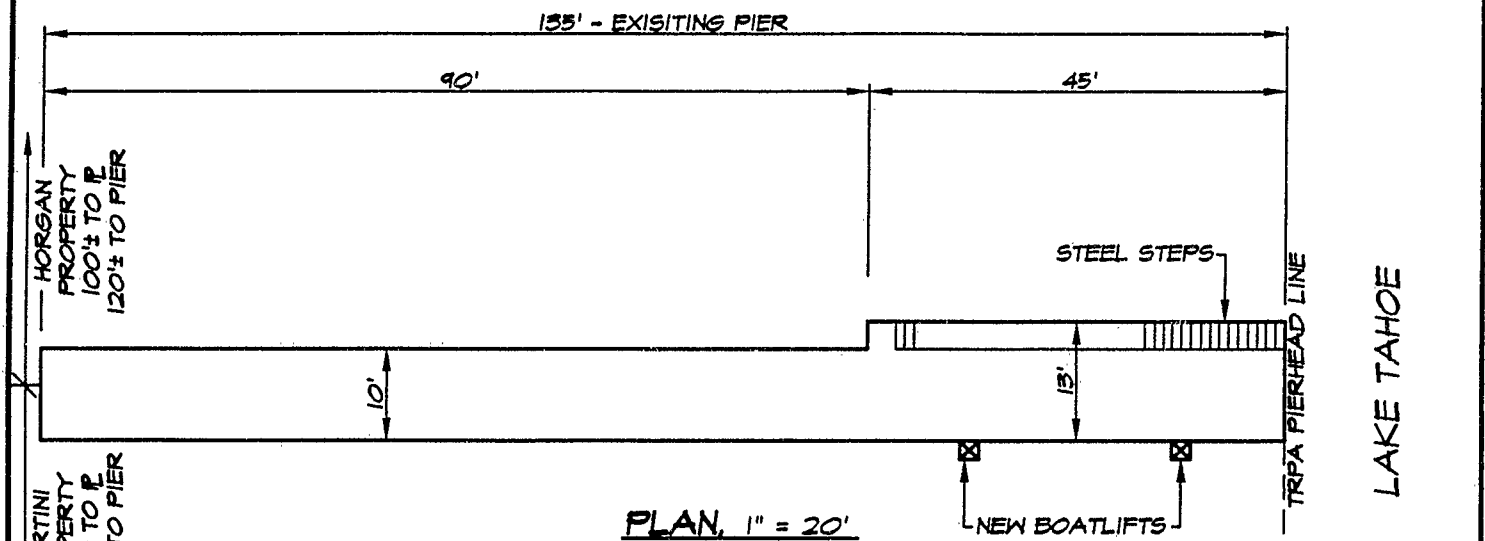

**PLAN, 1" = 20'**

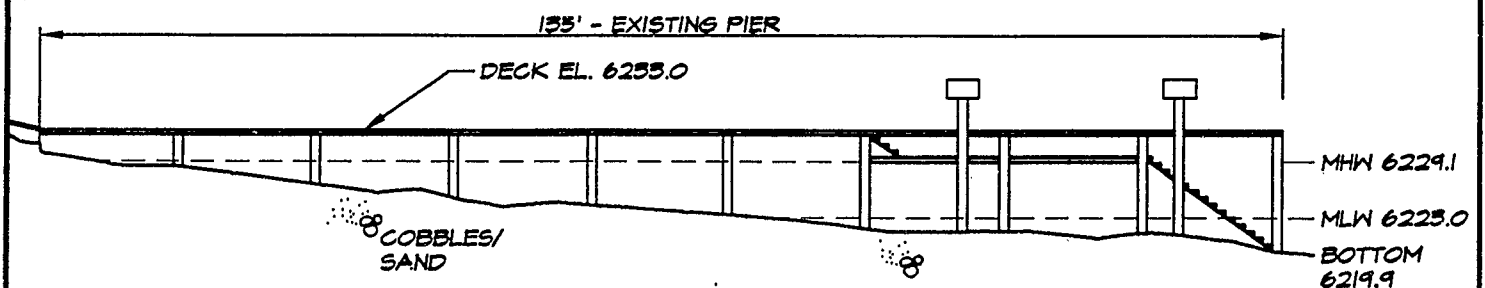

**PROFILE, 1" = 20'**

**MARTINI/HORGAN PIER MODIFICATION AND BOATLIFTS**

1655/1665 PINE CONE CIRCLE, INCLINE VILLAGE, NEVADA  
WASHOE COUNTY, APN: 130-241-39,40

THIS DRAWING  
IS FOR PERMIT  
PURPOSES ONLY



**KEVIN M. AGAN**  
Land & Shorezone Consultant  
Post Office Box 171  
Tahoe City, California 96145  
916.581.1640 Fax 916.581.1641

JANUARY 1996

SHEET 2 OF 2

PETER G. MORROS  
Director  
Department of Conservation  
and Natural Resources  
PAMELA B. WILCOX  
Administrator

BOB MILLER  
Governor



State Land Office  
State Land Use Planning Agency  
Address Reply to  
Division of State Lands  
Capitol Complex  
Carson City, Nevada 89710  
(702) 687-4363

199500724

STATE OF NEVADA  
DEPARTMENT OF CONSERVATION AND NATURAL RESOURCES

Division of State Lands

January 9, 1996

Robert Martini  
c/o Kevin Agan  
P.O. Box 171  
Tahoe City, California 96145

Re: APN 130-241-40  
Washoe County

Dear Mr. Martini:

Enclosed herewith is a TWENTY (20) year Permit No. LO461 under the name of Robert E. Martini, Edward J and Theresa Horgan to retain and repair one (1) existing multiple use pier and add two (2) boat hoists. Also enclosed is a FIVE (5) year Permit No. LO464 with a decal sticker (No. 1996/00560) for one (1) existing single residential use mooring buoy. Please note that your permits have been dated July 1, 1995, giving you credit for the fees that you have paid in advance.

If you have any questions or require any clarification, please contact this office.

Sincerely,

A handwritten signature in black ink that reads "Edward W. Bittleston".

Edward W. Bittleston  
Land Agent

EWB/kj

Enclosures

cc: (b) (6) U.S. Army Corps of Engineers  
Jim Lawrence, Tahoe Regional Planning Agency  
Richard T. Heap, Jr., Division of Wildlife

PERMIT NUMBER LO461

STATE OF NEVADA  
DEPARTMENT OF CONSERVATION AND NATURAL RESOURCES  
DIVISION OF STATE LANDS  
333 West Nye Lane, Room 118  
Carson City, Nevada 89710

THE STATE OF NEVADA, acting through the Division of State Lands pursuant to NRS 321.595 and NRS 322.100 does hereby grant a permit to:

Name: ROBERT E. MARTINI, EDWARD J. HORGAN AND THERESA HORGAN  
C/O KEVIN AGAN

Mailing Address: P.O. BOX 171  
TAHOE CITY, CALIFORNIA 96145

1. The physical address in which this facility is to be located is: \_\_\_\_\_  
1665 PINE CONE CIRCLE  
INCLINE VILLAGE, NEVADA

Parcel Number: 130-241-40 County: WASHOE  
SEC: 23 TWP: 16 NORTH RGE: 18 EAST

2. Permittee is authorized: TO RETAIN AND REPAIR ONE (1) EXISTING MULTIPLE USE PIER  
AND ADD TWO (2) BOAT HOISTS. ADD A CATWALK AND STEEL STEPS. THE STEEL STEPS  
SHOULDN'T EXTEND BEYOND ELEVATION 6223.0 FEET. THIS PERMIT ABROGATES STATE  
LANDS PERMIT NUMBER LO149.

3. Proof of financial responsibility in amount of: \$1,000,000.00  
has been established in the following manner: \_\_\_\_\_  
SAFECO INSURANCE COMPANY POLICY NUMBER 0S566092

4. Conditions for permit approval: SEE ATTACHED CONDITIONS

5. A permit given by the Division of State Lands does not give any property rights either in real estate or material nor does it obviate the necessity of obtaining federal, local or regional assent to the work authorized.

6. The public shall not be denied reasonable access to or the use of any State lands or facilities permitted herein.

PERMIT TERM: TWENTY (20) YEARS ; beginning: JULY 1, 1995 ;  
ending: JUNE 30, 2015 ; unless sooner terminated as provided.

ANNUAL FEE RATE: 1995 - \$400.00 FEE AS OF JULY 1, 1996 - \$62.50

Given under the hand of the Administrator of the Division of State Lands

this 5TH day of JANUARY 19 96



PAMELA B. WILCOX  
Administrator  
Division of State Lands  
PAMELA B. WILCOX

**PETER G. MORROS**  
*Director*  
Department of Conservation  
and Natural Resources  
**PAMELA B. WILCOX**  
*Administrator*

**BOB MILLER**  
*Governor*



State Land Office  
State Land Use Planning Agency  
*Address Reply to*  
Division of State Lands  
Capitol Complex  
Carson City, Nevada 89710  
(702) 687-4363

STATE OF NEVADA

DEPARTMENT OF CONSERVATION AND NATURAL RESOURCES

## Division of State Lands

### **ROBERT E. MARTINI, EDWARD J. HORGAN AND THERESA HORGAN MULTIPLE-USE PIER AND BOAT HOIST PERMIT NUMBER LO461 CONDITIONS**

1. This permit is subject to the acquisition of all local, regional, state and federal permits and approvals including, but not limited to, Tahoe Regional Planning Agency and U.S. Army Corps of Engineers permits and approvals.
2. The multiple-use pier and low level boat hoists must be constructed according to the attached approved plans.
3. No rocks or other material may be moved or relocated at or around the site of the pier and boat hoists.
4. The pier and boat hoists must be maintained in good repair at all times.
5. At no time will the permittees deny general public access to the waters of Lake Tahoe in, under and around the pier or other structures for fishing or other recreational uses.
6. The permittees understand and agree that the insurance coverage must remain in effect at all times. If the insurance coverage is allowed to expire, the permittees will be required to immediately remove the pier and boat hoists from Lake Tahoe.
7. A permit from the Division of State Lands is required prior to commencement of any future changes, relocation or expansion of the pier and/or boat hoists as approved under this permit.
8. No mooring buoys are permitted or allowed under this permit.
9. The permittees, their successors and assigns, understand and agree that the Division of State Lands is required, pursuant to NRS 322.120, to assess annual permit fees in the amount of SIXTY-TWO DOLLARS AND FIFTY CENTS (\$62.50) for one (1) existing multiple use pier in Lake Tahoe below elevation 6223.0 feet. No fee is assessed for the boat hoists. Said fees to be paid on or before July 1, 1996.
10. Failure to concur with or comply with any of the conditions contained herein will cause this permit to become invalid and require the immediate removal of the pier and boat hoists from Lake Tahoe.
11. This permit abrogates permit LO149.



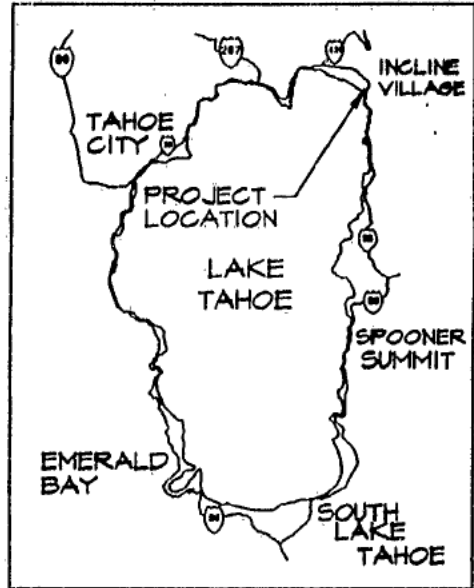
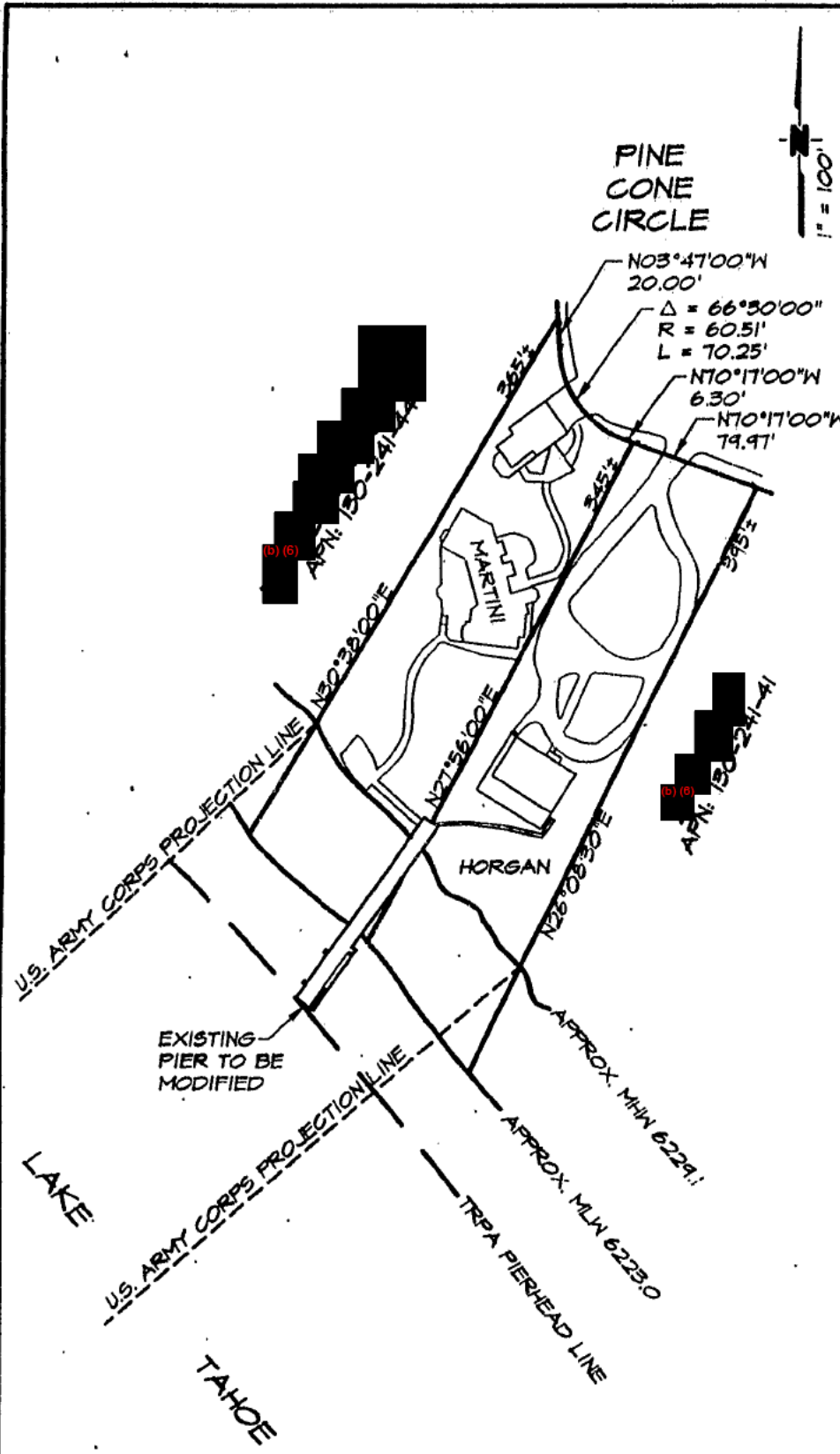

VICINITY MAP  
NO SCALE

NOTES

1) THE PROJECT INVOLVES THE MODIFICATION OF THE EXISTING MULTIPLE-USE PIERHEAD. THIS MODIFICATION INVOLVES RAISING THE PIER DECK, THE INSTALLATION OF A CATWALK, AND THE INSTALLATION OF TWO BOATLIFTS.

**MARTINI/HORGAN PIER MODIFICATION AND BOATLIFTS**  
 1655/1665 PINE CONE CIRCLE, INCLINE VILLAGE, NEVADA  
 WASHOE COUNTY, APN: 130-241-39,40

THIS DRAWING IS FOR PERMIT PURPOSES ONLY



**KEVIN M. AGAN**  
 Land & Shorezone Consultant  
 Post Office Box 171  
 Tahoe City, California 96145  
 916.581.1640 Fax 916.581.1641

JANUARY 1996  
 SHEET 1 OF 2

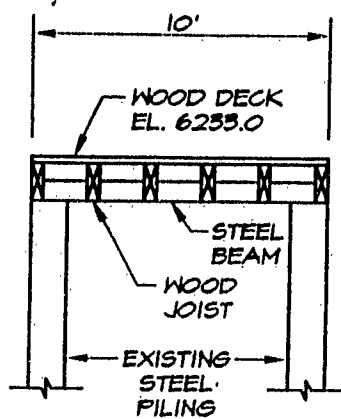

**WALKWAY SECTION**  
N.T.S.

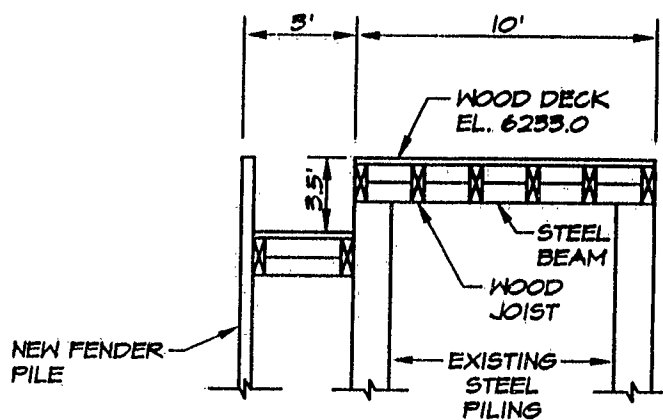

**PIERHEAD SECTION**  
N.T.S.

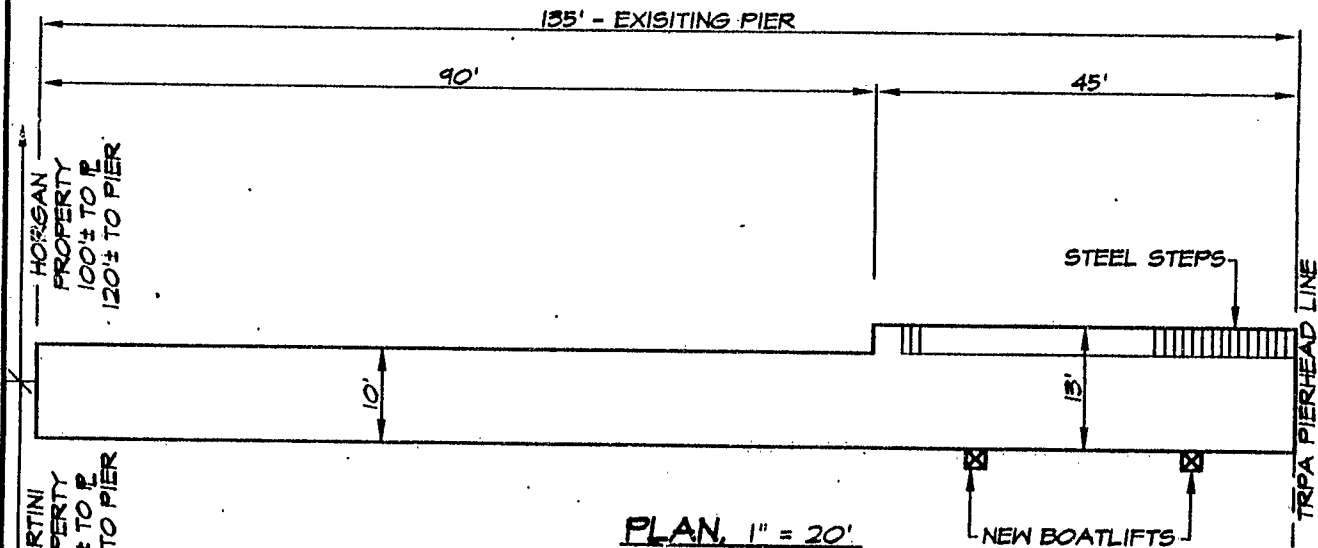

**PLAN, 1" = 20'**

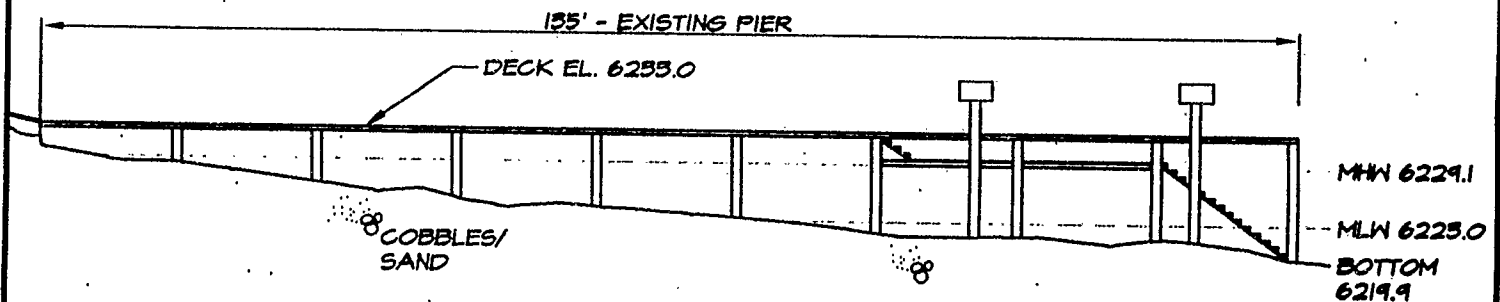

**PROFILE, 1" = 20'**

**MARTINI/HORGAN PIER MODIFICATION AND BOATLIFTS**  
1655/1665 PINE CONE CIRCLE, INCLINE VILLAGE, NEVADA  
WASHOE COUNTY, APN: 150-241-39,40

THIS DRAWING  
IS FOR PERMIT  
PURPOSES ONLY



**KEVIN M. AGAN**  
Land & Shorezone Consultant  
Post Office Box 171  
Tahoe City, California 96145  
916.581.1640 Fax 916.581.1641

JANUARY 1996

SHEET 2 OF 2

PORTION OF W<sup>2</sup>-SECTION 23  
T16N-R18E

130-24

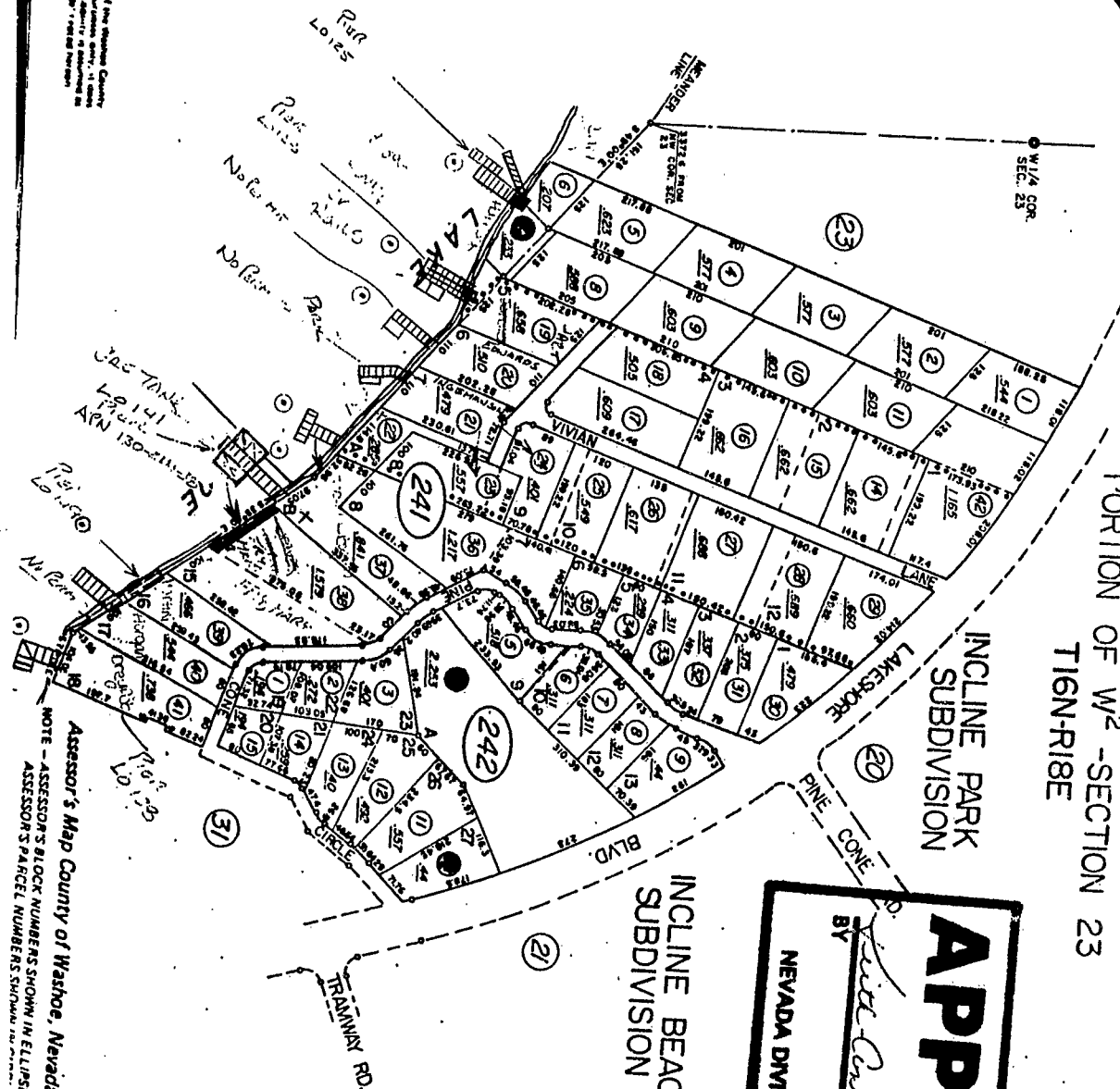

**APPROVED**  
 BY *Paula Ann Mowen*  
 NEVADA DIVISION OF STATE LANDS  
 DATE 1-4-96

Assessor's Map County of Washoe, Nevada  
 NOTE - ASSASSOR'S BLOCK NUMBERS SHOWN IN ELLIPSES  
 ASSASSOR'S PARCEL NUMBERS SHOWN IN CIRCLES

drawn by S.T.N. W.V. 6-7  
 revised 7-85

Notwithstanding to the use of the Division County  
 of the State of Nevada, the Assessor's Map, it shall  
 be the duty of the Assessor to cause the same to be  
 recorded by the State of Nevada.

PERMIT NUMBER LO461

STATE OF NEVADA  
DEPARTMENT OF CONSERVATION AND NATURAL RESOURCES  
DIVISION OF STATE LANDS  
333 West Nye Lane, Room 118  
Carson City, Nevada 89710

THE STATE OF NEVADA, acting through the Division of State Lands pursuant to NRS 321.595 and NRS 322.100 does hereby grant a permit to:

Name: ROBERT E. MARTINI, EDWARD J. HORGAN AND THERESA HORGAN  
C/O KEVIN AGAN

Mailing Address: P.O. BOX 171  
TAHOE CITY, CALIFORNIA 96145

1. The physical address in which this facility is to be located is: \_\_\_\_\_  
1665 PINE CONE CIRCLE  
INCLINE VILLAGE, NEVADA

Parcel Number: 130-241-40 County: WASHOE  
SEC: 23 TWP: 16 NORTH RGE: 18 EAST

2. Permittee is authorized: TO RETAIN AND REPAIR ONE (1) EXISTING MULTIPLE USE PIER  
AND ADD TWO (2) BOAT HOISTS. ADD A CATWALK AND STEEL STEPS. THE STEEL STEPS  
SHOULDN'T EXTEND BEYOND ELEVATION 6223.0 FEET. THIS PERMIT ABROGATES STATE  
LANDS PERMIT NUMBER LO149.

3. Proof of financial responsibility in amount of: \$1,000,000.00  
has been established in the following manner: \_\_\_\_\_  
SAFECO INSURANCE COMPANY POLICY NUMBER 0S566092

4. Conditions for permit approval: SEE ATTACHED CONDITIONS

5. A permit given by the Division of State Lands does not give any property rights either in real estate or material nor does it obviate the necessity of obtaining federal, local or regional assent to the work authorized.

6. The public shall not be denied reasonable access to or the use of any State lands or facilities permitted herein.

PERMIT TERM: TWENTY (20) YEARS; beginning: JULY 1, 1995;  
ending: JUNE 30, 2015; unless sooner terminated as provided.

ANNUAL FEE RATE: 1995 - \$400.00 FEE AS OF JULY 1, 1996 - \$62.50

Given under the hand of the Administrator of the Division of State Lands

this 5TH day of JANUARY 19 96.



PAMELA B. WILCOX  
Administrator  
Division of State Lands  
PAMELA B. WILCOX

**PETER G. MORROS**  
*Director*  
Department of Conservation  
and Natural Resources

**PAMELA B. WILCOX**  
*Administrator*

**BOB MILLER**  
*Governor*



State Land Office  
State Land Use Planning Agency  
*Address Reply to*  
Division of State Lands  
Capitol Complex  
Carson City, Nevada 89710  
(702) 687-4363

STATE OF NEVADA

DEPARTMENT OF CONSERVATION AND NATURAL RESOURCES

## Division of State Lands

### **ROBERT E. MARTINI, EDWARD J. HORGAN AND THERESA HORGAN MULTIPLE-USE PIER AND BOAT HOIST PERMIT NUMBER LO461 CONDITIONS**

1. This permit is subject to the acquisition of all local, regional, state and federal permits and approvals including, but not limited to, Tahoe Regional Planning Agency and U.S. Army Corps of Engineers permits and approvals.
2. The multiple-use pier and low level boat hoists must be constructed according to the attached approved plans.
3. No rocks or other material may be moved or relocated at or around the site of the pier and boat hoists.
4. The pier and boat hoists must be maintained in good repair at all times.
5. At no time will the permittees deny general public access to the waters of Lake Tahoe in, under and around the pier or other structures for fishing or other recreational uses.
6. The permittees understand and agree that the insurance coverage must remain in effect at all times. If the insurance coverage is allowed to expire, the permittees will be required to immediately remove the pier and boat hoists from Lake Tahoe.
7. A permit from the Division of State Lands is required prior to commencement of any future changes, relocation or expansion of the pier and/or boat hoists as approved under this permit.
8. No mooring buoys are permitted or allowed under this permit.
9. The permittees, their successors and assigns, understand and agree that the Division of State Lands is required, pursuant to NRS 322.120, to assess annual permit fees in the amount of SIXTY-TWO DOLLARS AND FIFTY CENTS (\$62.50) for one (1) existing multiple use pier in Lake Tahoe below elevation 6223.0 feet. No fee is assessed for the boat hoists. Said fees to be paid on or before July 1, 1996.
10. Failure to concur with or comply with any of the conditions contained herein will cause this permit to become invalid and require the immediate removal of the pier and boat hoists from Lake Tahoe.
11. This permit abrogates permit LO149.

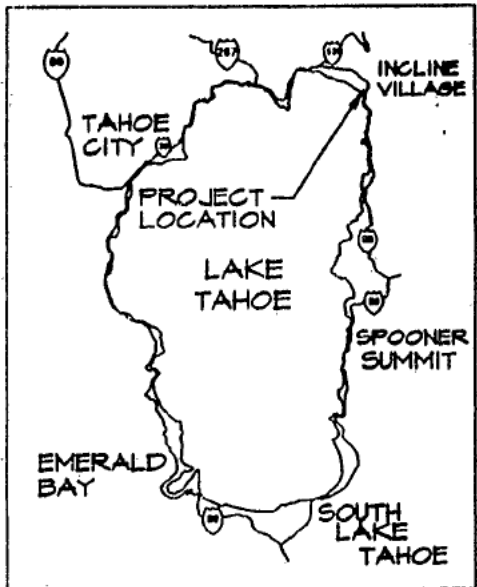
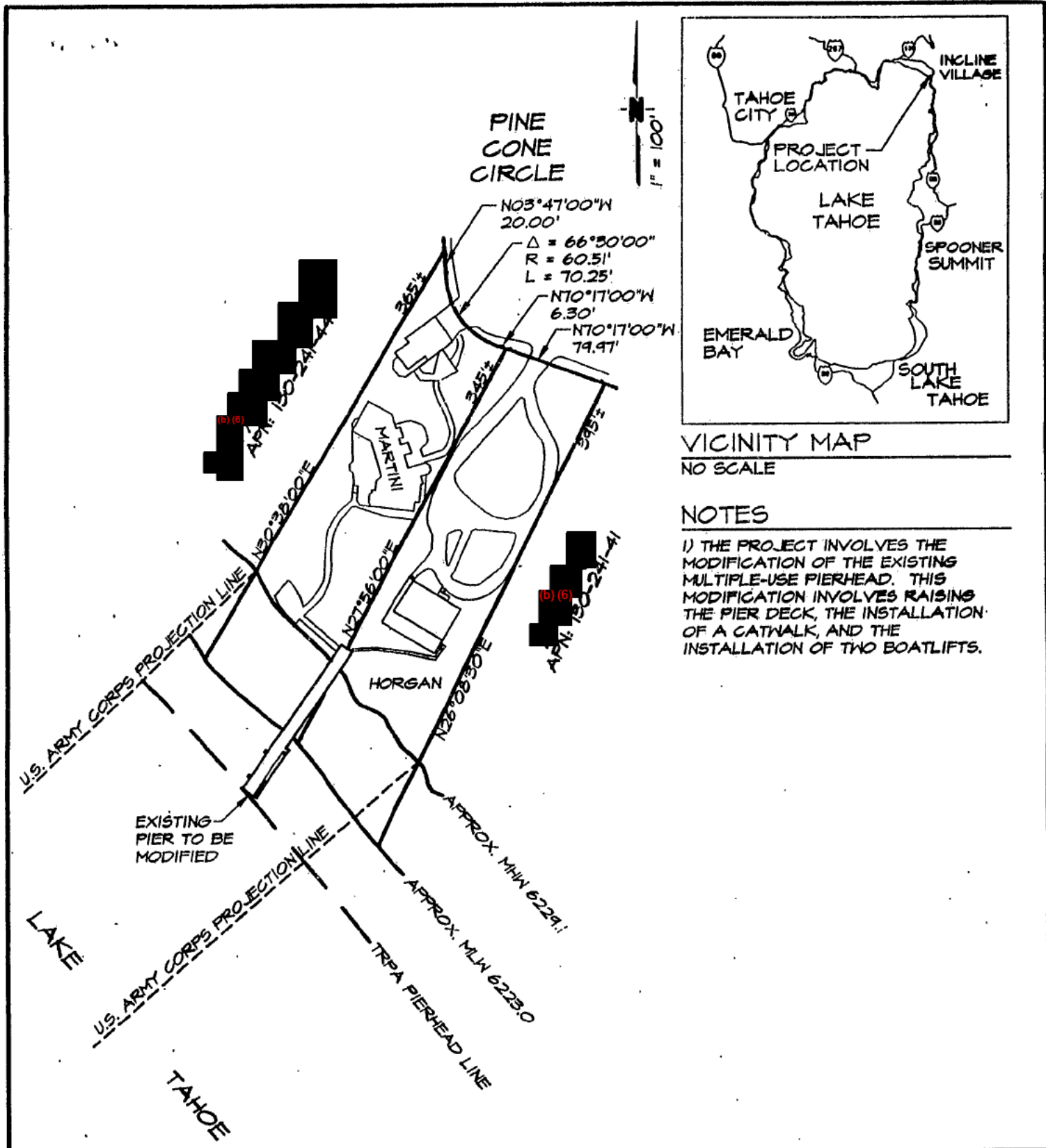

VICINITY MAP  
NO SCALE

NOTES

1) THE PROJECT INVOLVES THE MODIFICATION OF THE EXISTING MULTIPLE-USE PIERHEAD. THIS MODIFICATION INVOLVES RAISING THE PIER DECK, THE INSTALLATION OF A CATWALK, AND THE INSTALLATION OF TWO BOATLIFTS.

**MARTINI/HORGAN PIER MODIFICATION AND BOATLIFTS**  
 1655/1665 PINE CONE CIRCLE, INCLINE VILLAGE, NEVADA  
 WASHOE COUNTY, APN: 130-241-39,40

THIS DRAWING IS FOR PERMIT PURPOSES ONLY



**KEVIN M. AGAN**  
 Land & Shorezone Consultant  
 Post Office Box 171  
 Tahoe City, California 96145  
 916.581.1640 Fax 916.581.1641

JANUARY 1996  
 SHEET 1 OF 2

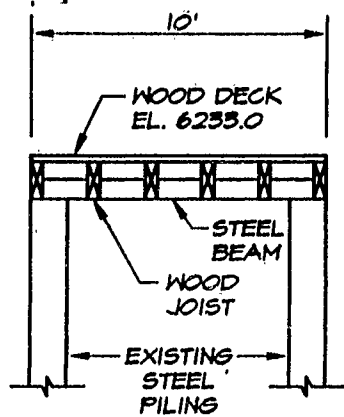

**WALKWAY SECTION**  
N.T.S.

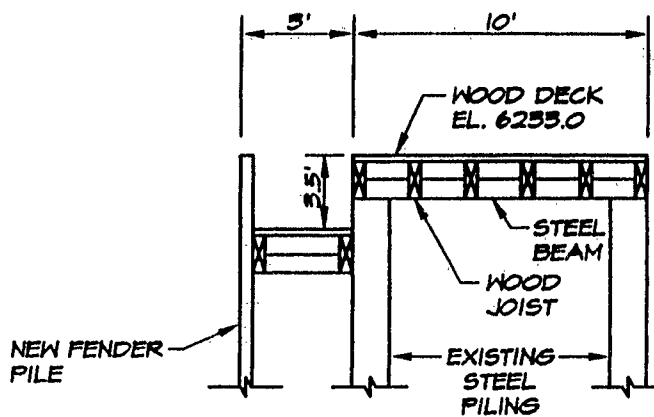

**PIERHEAD SECTION**  
N.T.S.

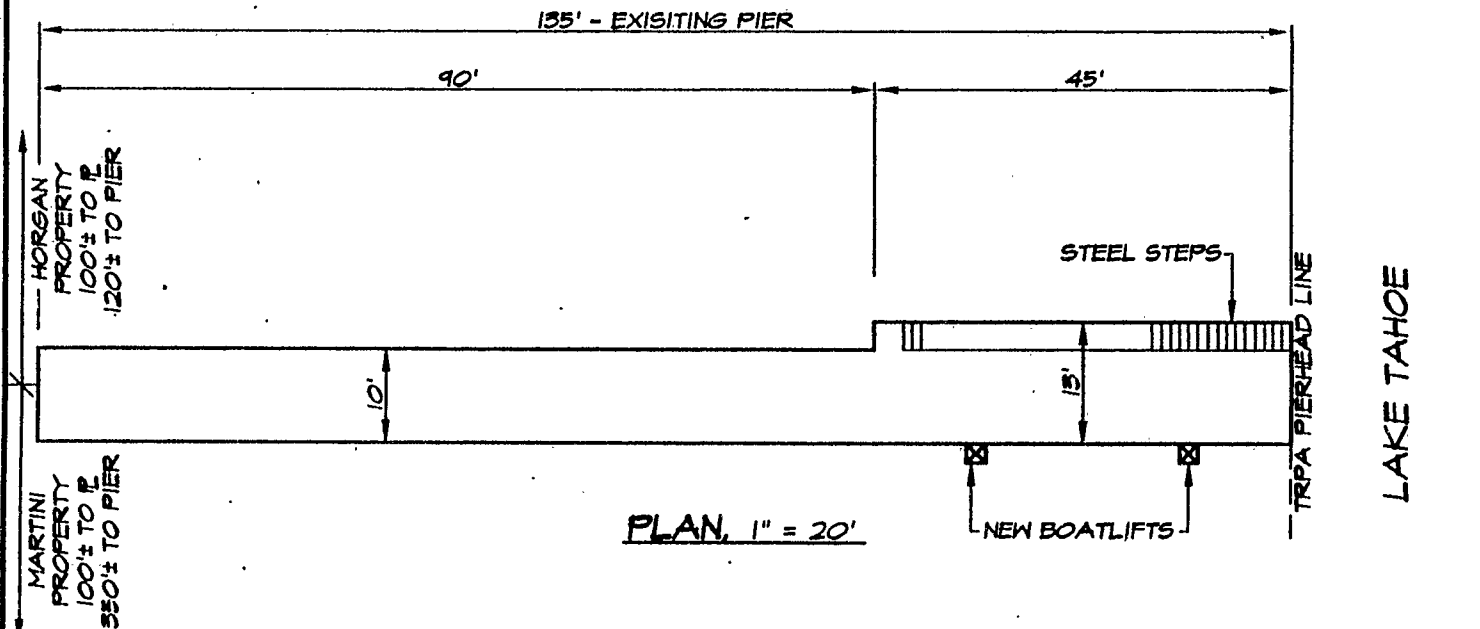

**PLAN, 1" = 20'**

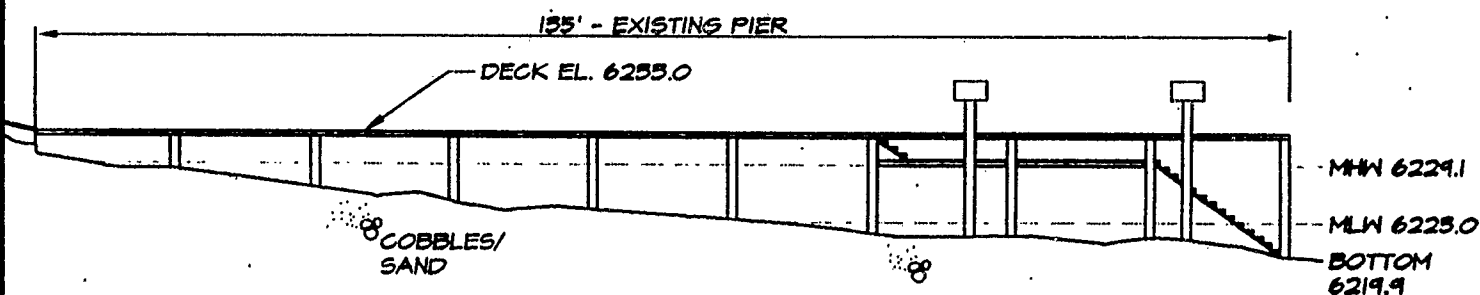

**PROFILE, 1" = 20'**

**MARTINI/HORGAN PIER MODIFICATION AND BOATLIFTS**

1655/1665 PINE CONE CIRCLE, INCLINE VILLAGE, NEVADA  
WASHOE COUNTY, APN: 130-241-39,40

THIS DRAWING  
IS FOR PERMIT  
PURPOSES ONLY



**KEVIN M. AGAN**  
Land & Shorezone Consultant  
Post Office Box 171  
Tahoe City, California 96145  
916.581.1640 Fax 916.581.1641

JANUARY 1996

SHEET 2 OF 2

PORTION OF W<sup>2</sup> - SECTION 23  
T16N-R18E

130-24

**APPROVED**  
BY *Walter C. M. ...*  
NEVADA DIVISION OF STATE LANDS  
DATE 1-4-96

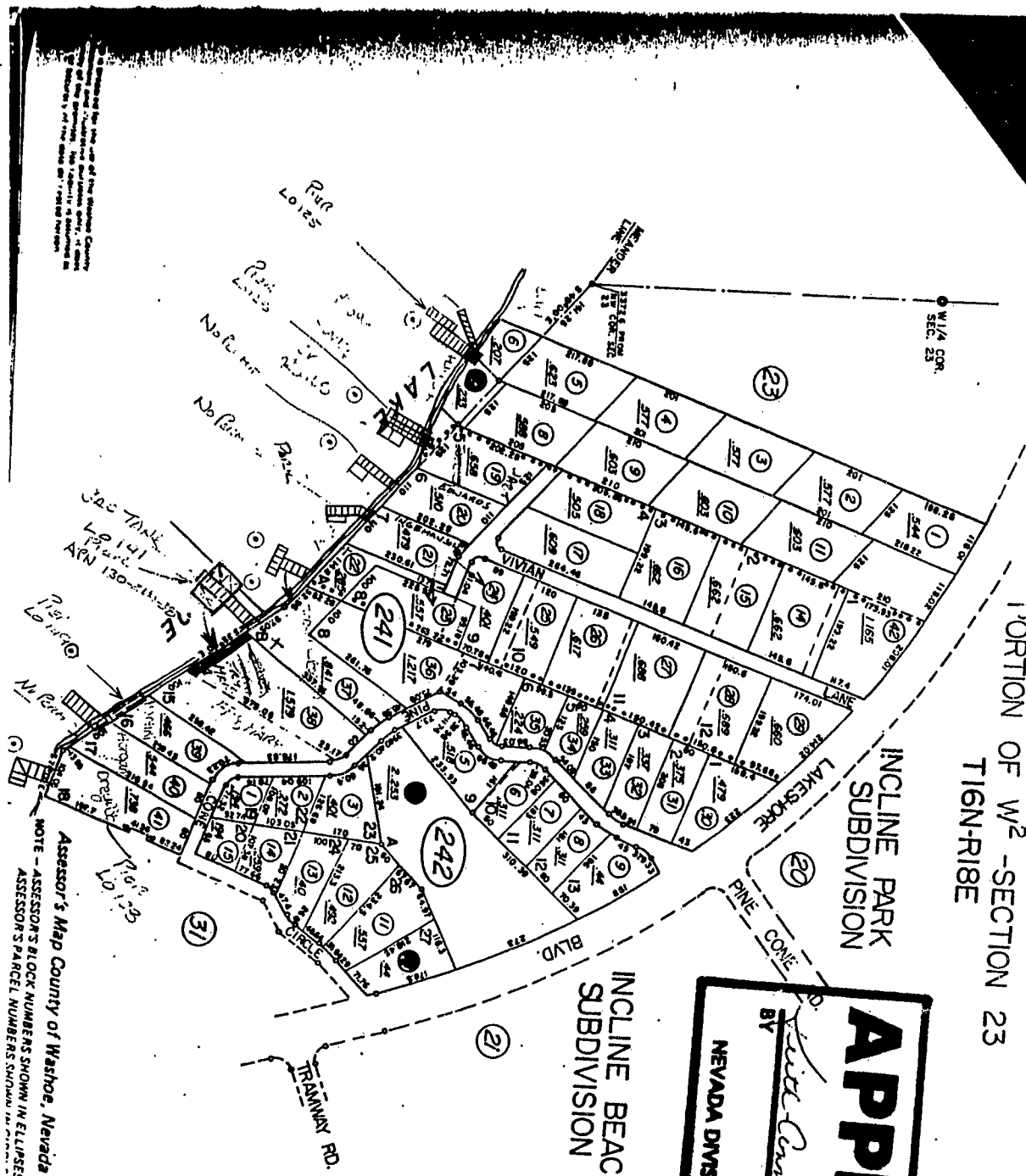

Assessor's Map County of Washoe, Nevada  
NOTE - ASSESSOR'S BLOCK NUMBERS SHOWN IN ELLIPSES  
ASSESSOR'S PARCEL NUMBERS SHOWN IN CIRCLES

drawn by S.T.V. M.V. 6-7  
revised 7-85

Assessor's Map County of Washoe, Nevada  
NOTE - ASSESSOR'S BLOCK NUMBERS SHOWN IN ELLIPSES  
ASSESSOR'S PARCEL NUMBERS SHOWN IN CIRCLES



PETER G. MORROS, Director  
L.H. DODGSON, Administrator  
(702) 687-4670  
TDD 687-4678

Administration  
Mining Regulation and Reclamation  
Water Pollution Control  
Facsimile 687-5856

Address Reply to:  
Capitol Complex  
Carson City, NV 89710

STATE OF NEVADA  
BOB MILLER  
Governor



REC'D  
NOV 17 1995

Waste Management  
Corrective Actions  
Federal Facilities  
Facsimile 885-0868

Air Quality  
Water Quality Planning  
Facsimile 687-6396

Located at:  
333 W. Nye Lane  
Carson City, NV 89710

DEPARTMENT OF CONSERVATION AND NATURAL RESOURCES  
DIVISION OF ENVIRONMENTAL PROTECTION

Capitol Complex  
Carson City, Nevada 89710

October 30, 1995

DEC 14 1995

199500724

Ronald R. Pacheco  
Division of State Lands  
333 W. Nye Lane  
Carson City, NV 89710

Dear Mr. Pacheco:

Nevada Division of Environmental Protection, Bureau of Water Quality Planning, has reviewed the application to permit the raising of a multiple use pier, a catwalk, steel steps to the lake and two (2) boat lifts as submitted by Robert E. Martine, APN 130-241-39 and Veronica P. Horgan, Edward J. Horgan and Thomas P. Horgan, APN 130-241-40. This agency has no comments to make at this time. If there are any changes or additions to this application, this agency must be notified and another review will be done.

If you have any questions regarding this project please feel free to contact me at (702)687-4670 extension 3091.

Sincerely,

A handwritten signature in cursive script, appearing to read "Garland Francis".

Garland Francis  
Environmental Management Specialist III  
Bureau of Water Quality Planning

cc: (b) (6) U.S. Army Corps of Engineers  
Jim Lawrence, TRPA

**TAHOE REGIONAL PLANNING AGENCY**308 Doria Court  
Elks Point, NevadaP.O. Box 1038  
Zephyr Cove, Nevada 89448-1038(702) 588-4547  
Fax (702) 588-4527  
Email: trpa@sierra.net**STATEMENT OF NO SIGNIFICANT EFFECT**

**PROJECT DESCRIPTION:** Martini/Horgan Pier Expansion      **APN:** 130-241-39  
**PERMITTEE(S):** Robert E. Martini and Edward J. Horgan      **FILE:** #960801  
**COUNTY/LOCATION:** Washoe/1655 and 1665 Pine Cone Circle, Incline Village, NV

**Staff Analysis:** In accordance with Article VI of the Tahoe Regional Planning Compact, as amended, and Section 6.3 of the TRPA Rules and Regulations of Practice and Procedure, the TRPA staff has reviewed the information submitted with the subject project. On the basis of this initial environmental evaluation, Agency staff has found that the subject project will not have a significant effect on the environment.

**Determination:** Based on the above-stated finding, the subject project is conditionally exempt from the requirement to prepare an Environmental Impact Statement. The conditions of this exemption are the conditions of permit approval.

  
\_\_\_\_\_  
TRPA Chairman or Executive Director/Designee

9-27-96  
\_\_\_\_\_  
Date

January 5, 1996

Regulatory Branch (199500724) 3296

Kevin Agan Land & Shorezone Consultant  
P.O. Box 171  
Tahoe City, California 96145

Dear Mr. Agan:

We have received the application you submitted on behalf of Robert Martini and Edward Horgan, for a Department of the Army permit to modify their multiple-use pier. The project is located in Lake Tahoe within Section 23, Township 16 North, Range 18 East at Washoe County Assessor's Parcel Numbers 130-241-39/40, Nevada.

The Sacramento District has issued General Permit Number 16 for construction, modification, and repair work in Lake Tahoe. A copy of the general permit is enclosed for your review. Based on the information you provided, it appears your proposal could be authorized under this permit provided you obtain approvals from the Tahoe Regional Planning Agency and all other required state and local agencies. When you have obtained the necessary approvals please remit them to this office. At that time we will issue a letter of authorization for your project.

If you have any questions concerning our general permit, please write to (b) (6), Room 1480, or telephone (916) 557-7772.

Sincerely,

(b) (6)  
Chief, Nevada Office

(b) (6)

Enclosure

Copies Furnished: w/o enclosure

Jim Lawrence, Tahoe Regional Planning Agency, P.O. Box 1038,  
Zephyr Cove, Nevada 89448-1038  
Environmental Services, Region II, Department of Fish and Game,  
1701 Nimbus Road, Rancho Cordova, California 95670  
Ed Bittleston, Nevada Division of State Lands, 333 West Nye Lane,  
Room 118, Carson City, Nevada 89710  
Mrs. Helen Denny, U.S. Coast Guard, Eleventh Coast Guard  
District, 501 West Ocean Blvd., Long Beach, California  
90822-5399  
Mr. Robert E. Martini, 1655 Pine Cone Circle, Incline Village,  
Nevada 89450  
Mr. Edward J. Horgan, 1665 Pine Cone Circle, Incline Village,  
Nevada 89450  
cc: Nev Off, Reg Br

199500724

**KEVIN M. AGAN**

LAND & SHOREZONE CONSULTANT

October 18, 1995

190203296 - Martini  
199500517  
190303296 Horgan

(b) (6)

U.S. Army Corps of Engineers  
C. Clifton Young Federal Building  
300 Booth Street  
Reno, NV 89509

**Subject: Pier Modification/Boatlifts - Martini/Horgan Properties  
Washoe County APN: 130-241-39, 40**

Dear (b) (6),

Attached for your review and approval are the signed application, submittal drawings, project narrative, construction method, and recorded grant deeds for the above referenced project.

The proposed work involves raising the existing pier deck, construction of one catwalk with steel steps down to the lake, and installation of two boatlifts for the multiple use pier. The proposed pier work should be eligible to meet the General Permit No. 16 (GP-016) requirements and the retainment of the existing mooring buoys have already received "grandfather" status from your agency

Please process this application at your earliest convenience. Should you have any questions or need to discuss this matter in greater detail, please feel free to give me a call.

Sincerely Yours,

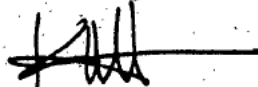

Kevin M. Agan

Land & Shorezone Consultant

KMA:  
Attachments

**APPLICATION FOR DEPARTMENT OF THE ARMY PERMIT  
(33 CFR 325)**

OMB APPROVAL NO. 0710-003  
Expires October 1996

Public reporting burden for this collection of information is estimated to average 5 hours per response, including the time for reviewing instructions, searching existing data sources, gathering and maintaining the data needed, and completing and reviewing the collection of information. Send comments regarding this burden estimate or any other aspect of this collection of information, including suggestions for reducing this burden, to Department of Defense, Washington Headquarters Service Directorate of Information Operations and Reports, 1215 Jefferson Davis Highway, Suite 1204, Arlington, VA 22202-4302; and to the Office of Management and Budget, Paperwork Reduction Project (0710-0003), Washington, DC 20503. Please DO NOT RETURN your form to either of those addresses. Completed applications must be submitted to the District Engineer having jurisdiction over the location of the proposed activity.

**PRIVACY ACT STATEMENT**

Authority: 33 USC 401, Section 10; 1413, Section 404. Principal Purpose: These laws require permits authorizing activities in, or affecting, navigable waters of the United States, the discharge of dredged or fill material into waters of the United States, and the transportation of dredged material for the purpose of dumping it into ocean waters. Routine Uses: Information provided on this form will be used in evaluating the application for a permit. Disclosure: Disclosure of requested information is voluntary. If information is not provided, however, the permit application cannot be processed nor can a permit be issued.

One set of original drawings or good reproducible copies which show the location and character of the proposed activity must be attached to this application (see sample drawings and instructions) and be submitted to the District Engineer having jurisdiction over the location of the proposed activity. An application that is not completed in full will be returned.

*(ITEMS 1 THRU 4 TO BE FILLED BY THE CORPS)*

1. APPLICATION NO. <u>199500724</u>	2. FIELD OFFICE CODE	3. DATE RECEIVED <u>10-20-95</u>	4. DATE APPLICATION COMPLETED
--	----------------------	-------------------------------------	-------------------------------

*(ITEMS BELOW TO BE FILLED BY APPLICANT)*

5. APPLICANT'S NAME <u>Robert E. Martini/Edward J. Horgan</u>	8. AUTHORIZED AGENT'S NAME AND TITLE <i>(an agent is not required)</i> <u>Kevin M. Agan Land &amp; Shorezone Consultant</u>
6. APPLICANT'S ADDRESS <u>Robert E. Martini 1655 Pine Cone Circle Incline Village, NV 89450</u>	9. AGENT'S ADDRESS <u>Post Office Box 171 Tahoe City, CA 96145</u>
7. APPLICANT'S PHONE NOS. W/AREA CODE a. Residence <u>(702) 831-7888</u> b. Business	10. AGENT'S PHONE NOS. W/AREA CODE a. Residence b. Business <u>(916) 581-1640</u>

**STATEMENT OF AUTHORIZATION**

I hereby authorize, Kevin M. Agan to act in my behalf as my agent in the processing of this application and to furnish, upon request, supplemental information in support of this permit application.

*Robert E. Martini*

APPLICANT'S SIGNATURE  
Robert E. Martini/Edward J. Horgan

*Edward J. Horgan*

DATE

**NAME, LOCATION AND DESCRIPTION OF PROJECT OR ACTIVITY**

12. PROJECT NAME OR TITLE <i>(see instructions)</i> <u>Martini/Horgan Multiple-Use Pier Modification. See attached project narrative and construction method for specific information.</u>	
13. NAME OF WATERBODY, IF KNOWN <i>(if applicable)</i> <u>Crystal Bay - Lake Tahoe</u>	14. PROJECT STREET ADDRESS <i>(if applicable)</i> <u>1655/1665 Pine Cone Circle Incline Village, NV 89450</u>
15. LOCATION OF PROJECT <u>Washoe</u> COUNTY <u>NV</u> STATE	

16. OTHER LOCATION DESCRIPTIONS, IF KNOWN, *(see instructions)*

APN: 130-241-39, 40

17. DIRECTIONS TO THE SITE

East end of Lakeshore Blvd in Incline Village. Approximately 0.25 miles west from the eastern intersection of Lakeshore Blvd and State Highway 28.

18. Nature of Activity (Description of project, include all features)

Modify existing pierhead, install two boatlifts, and retain mooring buoys. Please refer to attached project narrative and construction method for specific information regarding the proposed project.

19. Project Purpose (Describe the reason or purpose of the project, see instructions)

Private recreational use.

USE BLOCKS 20-22 IF DREDGED AND/OR FILL MATERIAL IS TO BE DISCHARGED

20. Reason(s) for Discharge

N/A

21. Type(s) of Material Being Discharged and the Amount of Each Type in Cubic Yards

N/A

22. Surface Area in Acres of Wetlands or Other Waters Filled (see instructions)

N/A

23. Is Any Portion of the Work Already Complete? Yes X No      IF YES, DESCRIBE THE COMPLETED WORK

Existing pier is permitted with the required agencies. Two buoys located lakeward of APN: 130-241-39 have been "grandfathered by the Corps."

24. Addresses of Adjoining Property Owners, Lessees, Etc., Whose Property Adjoins the Waterbody (if more than can be entered here, please attach a supplemental list).

East APN: 130-241-41

(b) (6)

West APN: 130-241-44

(b) (6)

25. List of Other Certifications or Approvals/Denials Received from other Federal, State or Local Agencies for Work Described in This Application.

AGENCY	TYPE APPROVAL*	IDENTIFICATION NUMBER	DATE APPLIED	DATE APPROVED	DATE DENIED
TRPA	Permit	130-241-39, 40	Pending		
NDSL	Permit	130-241-39, 40	Pending		

\*Would include but is not restricted to zoning, building and flood plain permits

26. Application is hereby made for a permit or permits to authorize the work described in this application. I certify that the information in this application is complete and accurate. I further certify that I possess the authority to undertake the work described herein or am acting as the duly authorized agent of the applicant.

\_\_\_\_\_  
SIGNATURE OF APPLICANT

\_\_\_\_\_  
DATE

Kevin M. Agan  
\_\_\_\_\_  
SIGNATURE OF AGENT

10/18/12  
\_\_\_\_\_  
DATE

Kevin M. Agan, Consultant

The application must be signed by the person who desires to undertake the proposed activity (applicant) or it may be signed by a duly authorized agent if the statement in block 11 has been filled out and signed.

18 U.S.C. Section 1001 provides that: Whoever, in any manner within the jurisdiction of any department or agency of the United States knowingly and willfully falsifies, conceals, or covers up any trick, scheme, or disguises a material fact or makes any false, fictitious or fraudulent statements or representations or makes or uses any false writing or document knowing same to contain any false, fictitious or fraudulent statements or entry, shall be fined not more than \$10,000 or imprisoned not more than five years or both.

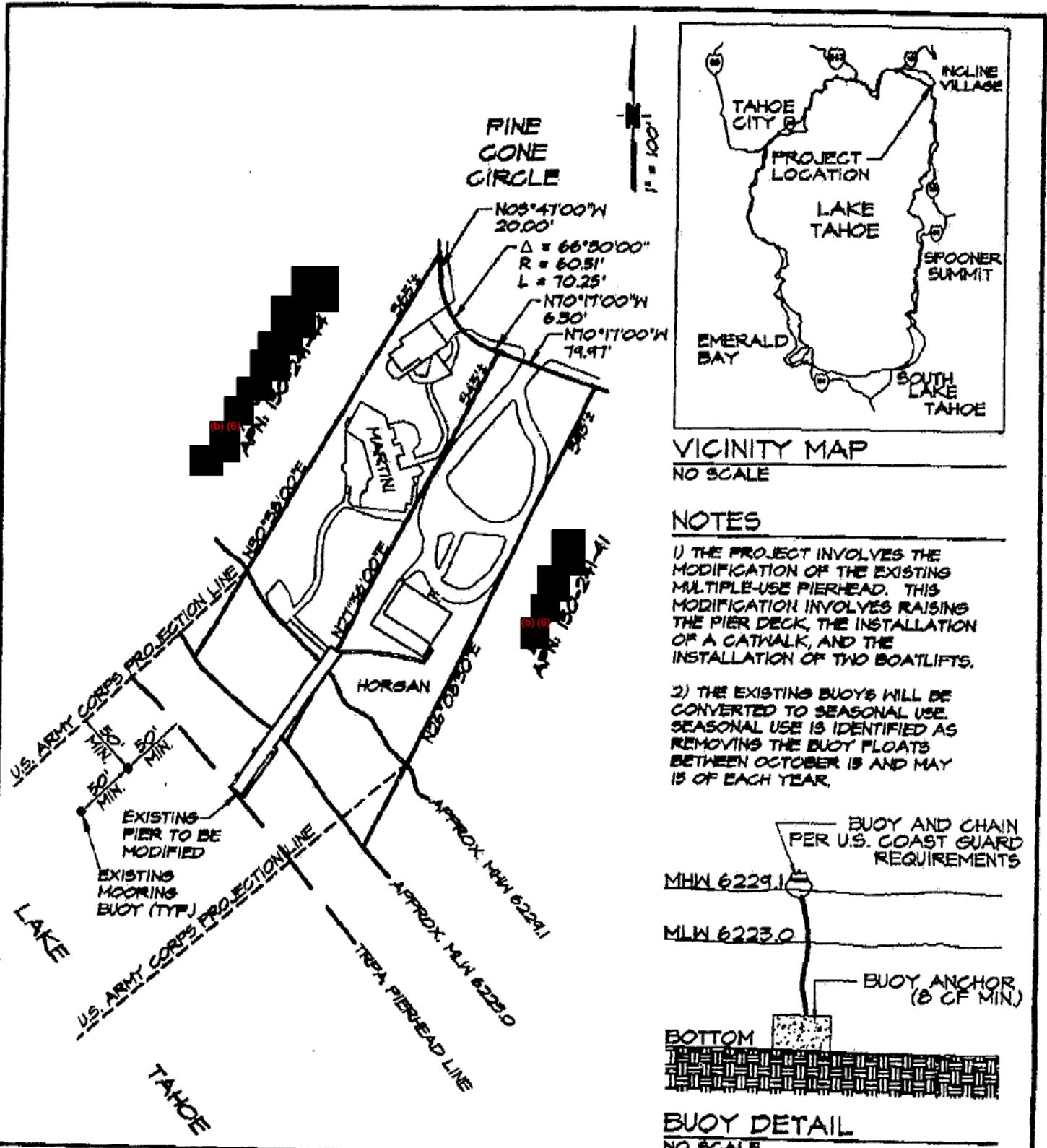

VICINITY MAP  
NO SCALE

- NOTES**
- 1) THE PROJECT INVOLVES THE MODIFICATION OF THE EXISTING MULTIPLE-USE PIERHEAD. THIS MODIFICATION INVOLVES RAISING THE PIER DECK, THE INSTALLATION OF A CATWALK, AND THE INSTALLATION OF TWO BOATLIFTS.
  - 2) THE EXISTING BUOYS WILL BE CONVERTED TO SEASONAL USE. SEASONAL USE IS IDENTIFIED AS REMOVING THE BUOY FLOATS BETWEEN OCTOBER 15 AND MAY 15 OF EACH YEAR.

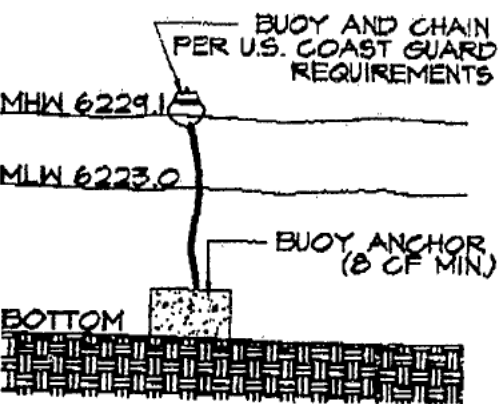

BUOY DETAIL  
NO SCALE

**MARTINI/HORGAN PIER MODIFICATION, BOATLIFTS, BUOYS**  
 1655/1665 PINE CONE CIRCLE, INCLINE VILLAGE, NEVADA  
 WASHOE COUNTY, APN: 150-241-59,40

THIS DRAWING IS FOR PERMIT PURPOSES ONLY



**KEVIN M. AGAN**  
 Land & Shorezone Consultant  
 Post Office Box 171  
 Tahoe City, California 96145  
 916.581.1640 Fax 916.581.1641

JANUARY 1996

SHEET 1 OF 2

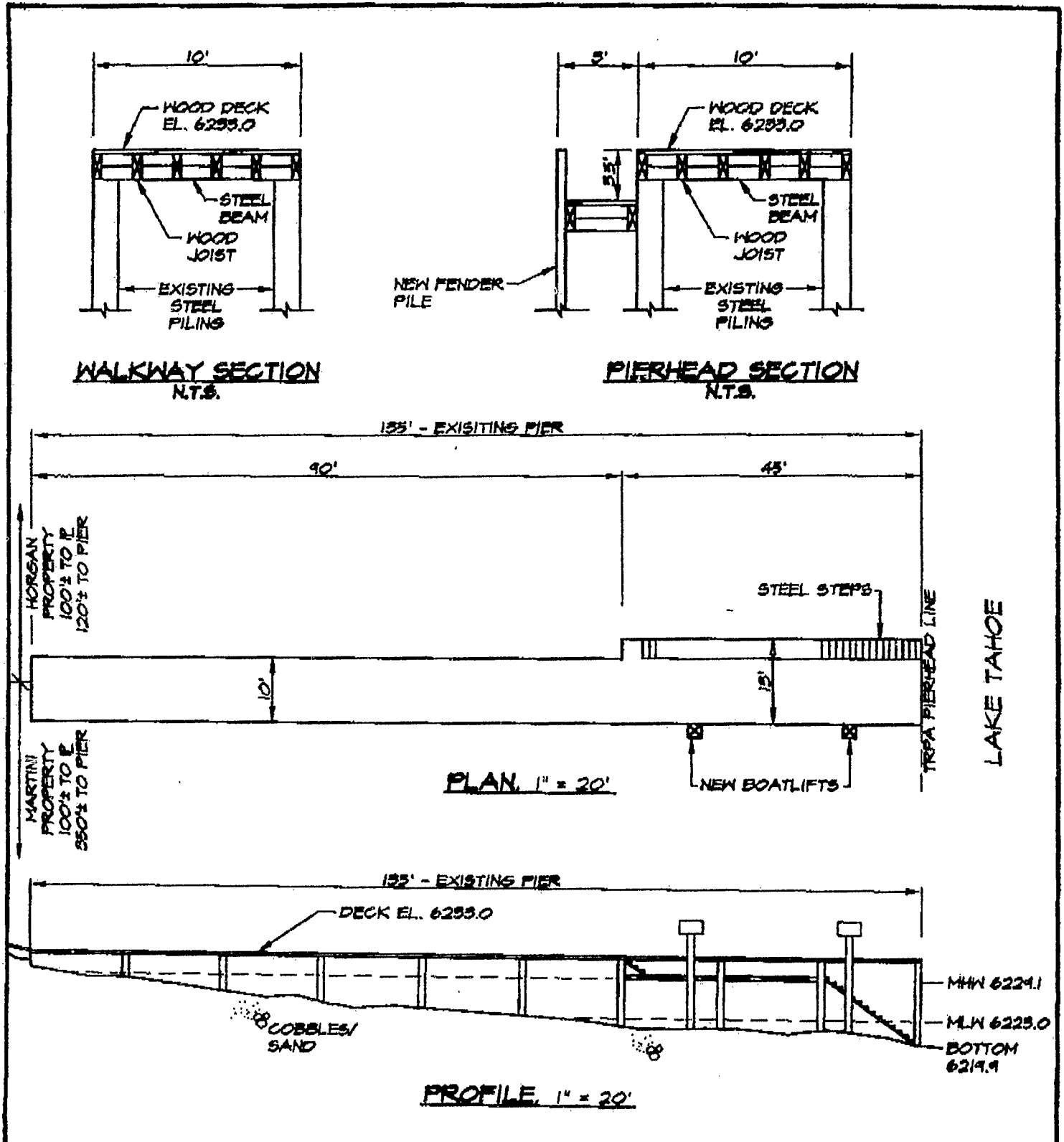

**MARTINI/HORGAN PIER MODIFICATION, BOATLIFTS, BUOYS**  
 1655/1665 PINE CONE CIRCLE, INCLINE VILLAGE, NEVADA  
 WASHOE COUNTY, APN: 150-241-09,40

THIS DRAWING  
 IS FOR PERMIT  
 PURPOSES ONLY



**KEVIN M. AGAN**  
 Land & Shorezone Consultant  
 Post Office Box 171  
 Tahoe City, California 96145  
 916.581.1640 Fax 916.581.1641

JANUARY 1996

SHEET 2 OF 2



## **MARTINI/HORGAN PIER MODIFICATION WASHOE COUNTY APN: 130-241-39, 40**

### **Project Narrative**

The project consists of raising the entire pier deck and modifying the pierhead with a catwalk and steel steps down to the lake. No pile driving is proposed for the pier with the exception of two boatlift installations and fender piling along the outboard edge of the catwalk. The work includes replacing the steel beams, wood joists and decking of the affected portion of the pier. The application includes the multiple-use recognition of this structure between the two lakefront parcels. No shoreline or lakebottom disturbance is anticipated with this project. Please refer to the submittal drawings for the visual representation of the proposed project.

### **Construction Method**

The repair work is to be performed by a rubber barge (i.e. Larc, etc.) with pile driver. All the work is proposed to be performed above the lakebottom with the exception of the two boatlift installations and small fender piling along the outboard edge of the proposed catwalk. No vehicular traffic either by barge or other large equipment will occur landward of the low water mark of Lake Tahoe. Tarps and/or a small boat(s) will be placed underneath the work areas to prevent discharge of waste material from entering into the lake. All construction wastes will be collected and disposed at the nearest dumpster or sanitary landfill site. Should the lakebottom sediment be disturbed, the rock cobble will be hand placed into a random pattern to restore the lakebottom to a natural condition which existed prior to the construction activity.

TO 000 BY (172)

APRIL R.P.T.T. 1201 <sup>30</sup>

425513

### Corporation Grant, Bargain, Sale Deed

HOODY'S, INC.

a corporation organized and existing under the laws of the State of Nevada, and having its principal place of business at Reno, Nevada

in consideration of TRK & NO/100 Dollars,

does hereby Grant, Bargain, Sell and Convey to ROBERT F. MARTINI, a married man

all that real property in the \_\_\_\_\_ County of Washoe State of Nevada, bounded and described as follows:

Lot 16 of INCLINE BEACH SUBDIVISION, Lake Tahoe, Washoe County, Nevada, according to the map thereof filed in the office of the County Recorder of Washoe County, State of Nevada, on August 5, 1944.

1000 354

TOGETHER WITH the rights, privileges and interest in connection with said lot now held or that may be conferred by Incline Beach Association, a Nevada Corporation which rights, if any, were acquired by said corporation, by deed recorded in Washoe County File No. 24354, Deed Records. ~~EXCEPTING THEREFROM~~ THAT PORTION THEREOF LYING BELOW THE NATURAL, ORDINARY, HIGH WATER LINE OF LAKE TAHOE. Subject property has Pier Permit #3296A permitting reconstruction of pier on lots 16 & 17 of Incline Beach Subdivision. Said permit recorded July 29, 1976 under File No. 419036, Book 994 page 99 in the office of the County Recorder of Washoe County, Nevada.

Together with all and singular the accretions, hereditaments and appurtenances therewith belonging or in anywise appertaining.

IN WITNESS WHEREOF said Grantor has caused its corporate name and seal to be affixed hereto by its \_\_\_\_\_ President and \_\_\_\_\_ Secretary thereunto duly authorized, this \_\_\_\_\_ day of September, 1976.

STATE OF NEVADA }  
COUNTY OF WASHOE } ss.

On September 1, 1976,  
personally appeared before me, a Notary Public,  
Chris Kabin

Who acknowledged that he executed the above instrument.

Signature Chris Kabin  
(Notary Public)

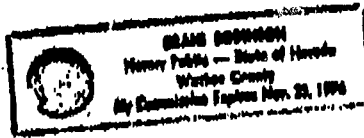

HOODY'S, INC.  
By Walter J. Scuri President  
Name (Typed or Printed)  
By \_\_\_\_\_ Secretary  
Walter B. Burtis  
Name (Typed or Printed)

ORDER NO. 118143-NE. BOOK NO. \_\_\_\_\_  
WHEN RECORDED MAIL TO: MR. Robert F. Martini  
P. O. Box 13, North Washoe Station, Silver  
Edge, New York 425513

OFFICIAL RECORDS  
WASHOE COUNTY, NEV.  
RECORDS RECEIVED BY  
THE REC. & CLERK  
SEP 10 1976 3:25 PM  
ARDE BROWN  
COUNTY RECORDER  
P.O. BOX 1007

425513

JAN 14 1969

1311214

*Deed*

FULL CONVEYANCE DEED OF  
ONE HALF INTEREST IN  
REAL PROPERTY IN TRUST

THIS DEED made this 10th day of January 1969  
between VERONICA P. HORGAN, of Reno, Nevada, Party of the  
First Part, and EDWARD J. HORGAN and THOMAS G. HORGAN  
as Trustees, both of Reno, Nevada, Parties of the Second  
Part,

W I T N E S S E T H:

That the said Party of the First Part does  
hereby grant, bargain, sell and convey in trust to EDWARD  
J. HORGAN and THOMAS G. HORGAN, as Trustees, an undivided  
one half interest in and to the following described real  
property in Washoe County, Nevada:

Lot 17 of INCLINE BEACH SUBDIVISION,  
LAKE TAHOE, WASHOE COUNTY, NEVADA,  
according to the official map thereof,  
filed in the office of the County  
Recorder of Washoe County, Nevada, on  
August 5, 1944, and

A right-of-way over part of Lot 16  
and Lot 17 of Incline Beach Subdivision,  
Washoe County, Nevada, according to the  
official map thereof filed in the Office  
of the County Recorder of Washoe County,  
Nevada, on August 5, 1944, lying within  
five feet of the boundary line between  
Lots 16 and 17 and within thirty feet  
of Lake Tahoe and over the entirety of  
a pier which is partly on Lot 16 and 17  
and partly extended into Lake Tahoe for  
the purpose of access to and use of the  
pier, which rights run with the respective  
lots.

TOGETHER WITH, all and singular, one half the  
tenements, hereditaments and appurtenances thereunto  
belonging or in anywise appertaining, and the reversion  
and reversions, remainder and remainders, rents, issues  
and profits thereof.

BOOK 366 PAGE 71

JAN 1 1969

TO HAVE AND TO HOLD, all and singular, one half the above described premises, together with the appurtenances, unto the said parties of the second part, and to their heirs and assigns forever, as trustees.

IN WITNESS WHEREOF, the said Party of the First Part has hereunto signed her name the day and year first above written.

*Veronica P. Morgan*  
Veronica P. Morgan

BOOK 388 PAGE 72

STATE OF NEVADA )  
COUNTY OF WASHOE ) ss.

On January 10, 1969 personally appeared before me, a notary public, VERONICA P. HORGAN who acknowledged that she executed the above instrument.

*Charles Fox*  
Notary Public

C. FOX  
NOTARY PUBLIC  
JAN 14 1969

# 134214  
OFFICIAL RECORDS  
WASHINGTON  
JAN 14 3 41 PM '69  
OFF. OF RECORDS  
F-1000 02

LOUIS BRIDGES  
GOLDWATER, TRENCH  
WILL AND MORTGAGE  
RECORDERS  
FEB 17 1969

PETER G. MORROS  
*Director*  
Department of Conservation  
and Natural Resources

PAMELA B. WILCOX  
*Administrator*

BOB MILLER  
*Governor*



State Land Office  
State Land Use Planning Agency  
*Address Reply to*  
Division of State Lands  
Capitol Complex  
Carson City, Nevada 89710  
(702) 687-4363

STATE OF NEVADA  
DEPARTMENT OF CONSERVATION AND NATURAL RESOURCES  
**Division of State Lands**

October 23, 1995

**MEMORANDUM**

TO: Richard T. Heap, Jr., Division of Wildlife  
R. Michael Turnipseed, Division of Water Resources  
Lewis H. Dodgion, Division of Environmental Protection  
Eugene M. Hattori, State Historic Preservation Office

FROM: Ronald R. Pacheco, Engineering Technician IV *RRP*

SUBJECT: APPLICATION AT LAKE TAHOE APN 130-241-39 AND 130-241-40

Attached is an application to permit the raising of a multiple use pier, a catwalk, steel steps to the lake and two boat lifts as submitted by Robert E. Martini (APN 130-241-39) and Veronica P. Horgan, Edward J. Horgan and Thomas P. Horgan (APN 130-241-40) located in Section 23, Township 16 North, Range 18 East, at 1655/1665 Pine Cone Circle, Incline Village, Washoe County, Nevada.

Please examine the application along with supporting documentation and submit any comments you may have in writing to this office on or before November 23, 1995. If we do not hear from you by this date, it will be assumed you have no comment.

Thank you for your attention and assistance concerning this matter.

RRP/kj

Attachments

cc: (b) (6) U.S. Army Corps of Engineers  
Jim Lawrence, Tahoe Regional Planning Agency

(b) (6)

STATE OF NEVADA

DIVISION OF  
STATE LANDS

**APPLICATION FOR DIVISION OF STATE LANDS PERMIT**

'95 OCT 20 AIO :29

*FIVE* copies of original drawings which show the location and character of the proposed activity must be attached to this application.

APPLICATION NUMBER (TO BE ASSIGNED BY DIVISION):	2. DATE:
	MONTH DAY YEAR

NAME OF APPLICANT:  
Robert E. Martini (APN: 130-241-39)  
Veronica P. Horgan, Edward J. Horgan, Thomas P. Horgan (APN: 130-241-40)

HAILING ADDRESS: Robert E. Martini 1655 Pine Cone Circle Incline Village, NV 89450	c/o Kevin M. Agan, Consultant Post Office Box 171 Tahoe City, CA 96145
---	--

TELEPHONE NUMBER: (702) 831-7888	ASSESSOR'S PARCEL NUMBER: 130-241-39, 40
-------------------------------------	---

PROJECT LOCATION: TWP. 16N RGE. 18E SEC. 23

ADDRESS: 1655/1665 Pine Cone Circle CITY: Incline Village COUNTY: Washoe

Describe the proposed activity, its purpose and intended use, including a description of the type of structures, if any to be erected on fills, or pile or float-supported platforms, and the type, composition and quantity of materials to be discharged or dumped and means of conveyance.

See attached project narrative and construction method for specific information regarding the proposed project.

8. PROPOSED USE:

PRIVATE  PUBLIC  COMMERCIAL  INDUSTRIAL  OTHER  (EXPLAIN IN REMARKS)

9. NAME AND ADDRESSES OF ADJOINING PROPERTY OWNERS:

East: APN: 130-241-41 (b) (6)

West: APN: 130-241-44 (b) (6)

10. NAME OF WATERWAY AT LOCATION OF PROJECT:

Crystal Bay - Lake Tahoe

DATE PROJECT IS EXPECTED TO BE COMPLETED: Summer 1996

12. HAS ANY PORTION OF THE PROJECT FOR WHICH AUTHORIZATION IS SOUGHT BEEN COMPLETED?

YES  NO  IF YES, GIVE DETAILS IN REMARKS SECTION.

13. LIST ALL AGENCIES WHO HAVE APPROVED PROJECT:

ISSUING AGENCY	TYPE OF APPROVAL	IDENTIFICATION NUMBER	DATE OF APPLICATION	DATE OF APPROVAL
TRPA	Pier Repair	APN: 130-241-39		07/08/86
Corps	Pier Repair	NO3-149		07/16/86
NDSL	Pier Repair	LO:149		08/04/86

14. HAS ANY AGENCY DENIED APPROVAL FOR THE ACTIVITY DESCRIBED HEREIN OR FOR ANY ACTIVITY DIRECT

RELATED TO THE ACTIVITY DESCRIBED HEREIN? YES  NO  (IF "YES" EXPLAIN IN REMARKS SECTION)

15. REMARKS:

The pier and one buoy has been approved by the Nevada Division of State Lands.

Two buoys have been grandfathered for APN: 130-241-39 by the U.S. Army Corps of Engineers (authorization letter attached).

16. Application is hereby made for a permit or permits to authorize the activities described herein. I certify that I am familiar with the information contained in this application, and that to the best of my knowledge and belief such information is true, complete and accurate. I further certify that I possess the authority to undertake the proposed activities.

  
SIGNATURE OF APPLICANT  
Kevin M. Agan, Consultant  
Authorized Representative

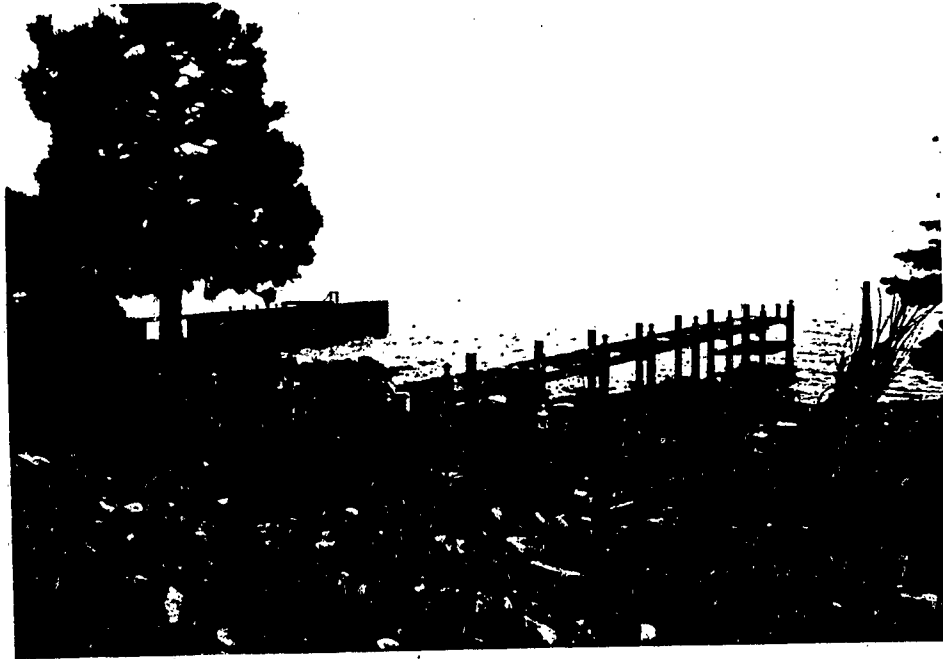

VIEWING EXISTING PIER FROM THE MARTINI PROPERTY

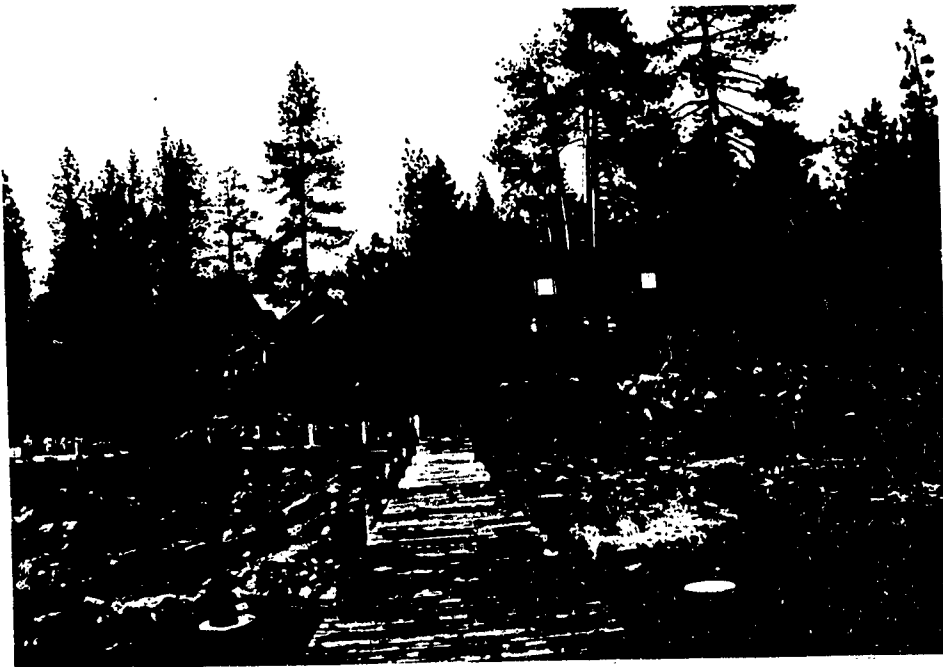

VIEWING THE MARTINI AND HORGAN PROPERTIES FROM THE EXISTING PIER



## **MARTINI/HORGAN PIER MODIFICATION WASHOE COUNTY APN: 130-241-39, 40**

### **Project Narrative**

The project consists of raising the entire pier deck and modifying the pierhead with a catwalk and steel steps down to the lake. No pile driving is proposed for the pier with the exception of two boatlift installations and fender piling along the outboard edge of the catwalk. The work includes replacing the steel beams, wood joists and decking of the affected portion of the pier. The application includes the multiple-use recognition of this structure between the two lakefront parcels. No shoreline or lakebottom disturbance is anticipated with this project. Please refer to the submittal drawings for the visual representation of the proposed project.

### **Construction Method**

The repair work is to be performed by a rubber barge (i.e. Larc, etc.) with pile driver. All the work is proposed to be performed above the lakebottom with the exception of the two boatlift installations and small fender piling along the outboard edge of the proposed catwalk. No vehicular traffic either by barge or other large equipment will occur landward of the low water mark of Lake Tahoe. Tarps and/or a small boat(s) will be placed underneath the work areas to prevent discharge of waste material from entering into the lake. All construction wastes will be collected and disposed at the nearest dumpster or sanitary landfill site. Should the lakebottom sediment be disturbed, the rock cobble will be hand placed into a random pattern to restore the lakebottom to a natural condition which existed prior to the construction activity.